

# Renewable Energy's Potential Scrutiny by PVSYST and RETSCREEN softwares

## Case study: Khoy City, Iran

H. Ashofteh\* and A. Behzadi Forough

*Amirkabir University of Technology, Tehran, Iran.*

Received Date 08 October 2021; Revised Date 10 December 2021; Accepted Date 02 March 2022

\*Corresponding author: [hoseinashofteh69@gmail.com](mailto:hoseinashofteh69@gmail.com) (H. Ashofteh)

### Abstract

Energy is one of the most critical factors in economic development but achieving a sustainable development is impossible without environmental protection and improving the economic conditions. If a country is dependent on energy, any structural reform policies to reduce energy consumption may reduce the economic growth. Saving energy consumption, and the development and application of alternative technologies, especially renewable energy, has a significant role in controlling and reducing the consumption of fossil energy carriers, and consequently, reducing the emission of environmental pollutants and achieving a sustainable development. This article deals with the feasibility of constructing the renewable energy power plants in the Khoy city. First, using the RETSCREEN software, the economic and environmental conditions of construction of renewable energy power plants in the Khoy city are examined. Using the PVSYST software, the requirements for constructing the solar power plants are discussed in a specialized way. In this work, the inflation rate is 12% and the interest rate is 4%. The construction of solar and geo-thermal power plants in this city can be prioritized based on the results obtained. The solar power plant has a production capacity of 30 MW. 212194 m of land and a capital of 40 million dollars are required to construct this solar power plant. The pay-back period of this project in the Khoy city is estimated at 25 years.

**Keywords:** *Geothermal power plant, solar power plant, RET screen.*

## 1. Introduction

### 1.1. Overview

The global energy demand has been increasing steadily since the beginning of the last century due to the growing societal requirements and many diverse industrial activities. In the last 40 years, the world's energy demand has doubled, and in 2013, the global final energy consumption increased by 2.3% from the previous year to around 9,300 Mtoe (equalling to 390 EJ). Even though the development of renewable energy sources has been increasing, more than 80% of the total energy still comes from non-renewable fossil fuels like oil, coal, and natural gas, which are the major contributors to the greenhouse gas (GHG) emissions. In 2012, the energy use of the CO<sub>2</sub> emitting energy sources increased by an additional 1.4% from the year before (IEA, 2013, 2016; BP2016). With the growing demand for energy in the world today, expanding 2.4% annually, the interest in renewables technologies are growing fast [1]. When installing renewables, there is a

great potential to have significant reductions in emissions, as well as cost savings [2].

The models and tools that have been developed for renewable energy are used to assess, analyze, and optimize the potential energy and cost impact of the renewable energy and energy efficiency technologies [3].

These tools can be applied on many different levels such as local, district, and regional. These models differ in scale and complexity, as well as the inputs that the software requires to generate the intended outputs [4].

The models need to balance simplicity and ease of use; accuracy, precision, and representativeness; and data granularity [5].

Many models make performance estimates based on the installation and operating costs and system design parameters that you specify as the inputs into the model. The general technical inputs include site location and resource data (weather information) [6], system components [7],

electricity rates, and electric load (energy usage per month) [7].

Due to the environmental concerns of fossil fuel consumptions across the world, most of the countries are looking for alternative energy resources [25].

Relentless environmental concerns, steep hike in fossil fuel price, and increasing demand of non-renewable fossil fuel consumption have dramatically increased the global search for alternative energies. The world requests are ever growing energy supplies in order to sustain economic development and improvement. Renewable and sustainable energy ever more has become accepted and has established a decisive place in the energy system of the world due to the ecologically responsive insight and a decrease in the equipment expenses [27].

Energy is a vital issue for the social welfare and economic growth of the countries. The energy sources are divided into two main groups: non-renewable and renewable energy sources. There are four main types of non-renewable energy sources: oil, natural gas, coal, and nuclear energy. Non-renewable fuels have been used as the leading resource in order to obtain energy but their use has numerous adverse effects such as global warming and air pollution. Meanwhile, non-renewable resource exhaustion has also been identified as an upcoming challenge. Therefore, numerous countries are exploring the renewable energy sources in order to resolve all these subjects. The renewable sources are wind energy, hydro-energy, geo-thermal energy, solar energy, and biomass energy [26].

The growing consumption of natural gas resources, on the one hand, and the steady growth in demand for energy, especially electricity, on the other hand, have created shortcomings in the country's electricity supply system in a way that could even affect the recent power outages. Various segments were observed during the troubled summer season [8].

Monthly statistics released by the Tavanir Company for October 2018 show that the number of electricity subscribers in the country increased by 3.1% in September 2018 compared to the same period in 2017, and by 0.3% compared to August 2017. Given the increasing demand for electricity in the country, a solution is required to be considered. According to the energy balance sheet published annually by the International Energy Agency (IEA), much of the world's renewable energy continues to be supplied from the non-renewable sources. After nearly half a century, the

share of non-renewable energy in the energy supply has not changed significantly.

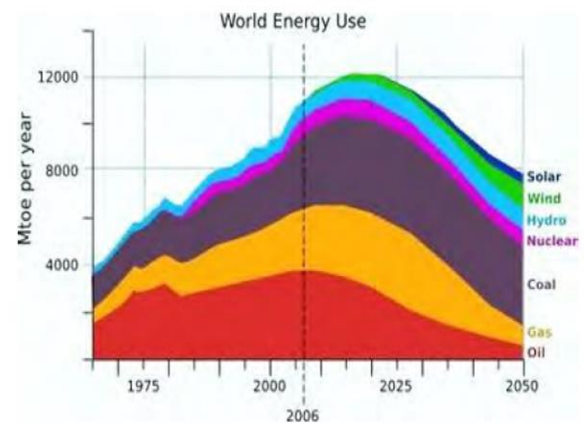

Figure 1. World energy use.

## 1.2. Previous reviews

Vreenegeer, Hensen, and de Vries [28] have worked on the advantages and disadvantages of eleven simulation tools (not all being renewable energy related), which are all different from the tools reviewed in this paper. The tools discussed in their research work primarily relate to the district-level modeling and how energy is calculated. The objective of this work was to develop a district evaluation model based on the energy performance to support housing associations in choosing the optimal renovation solution.

Kandt *et al.* [29] completed a comparative analysis of seven different solar mapping tools in 2010. This research work showed how the modeling tools changed over time, and described the new commercially available tools. They felt it was important to assess each individual modeling tool based on its accuracy and portrayal of PV potential.

LalwaniR and D.P. Kothari [30] expressed that RETScreen is a result of augmentation of various proficient from the Canadian government, industry, and academia. It is a decision support tool. Application of the software is to assay the energy production and savings, costs, emission reductions, financial viability and risk for various types of renewable-energy and energy-efficient technologies (RETs). It facilitates modeling and analyzing of any clean energy project for the engineers, architects, and financial planners. That is why RETScreen is the absolute product of its kind. It provides a five-step standard analysis including energy analysis, cost analysis, emission analysis, financial analysis, and sensitivity/risk analysis for the decision-makers.

Eventually, sustainability encompasses many dimensions such as environmental, economic, and social, which form the aspects of a sustainable development; from an ecological viewpoint, the activity of the current generation should be such that soil fertility, for example, is not reduced or even improved. From an economic viewpoint, the current generation must use the resources in a way that the future generations will enjoy and their own. Finally, from a social viewpoint, there is sustainability when it creates a bond between the social groups, and contributes to the health and well-being of the people in the community [10]. The results obtained show that renewable energies from the environmental, economic, and social viewpoints can lead to a sustainable development. The recent efforts in the public and private sectors to build renewable power plants and also government support schemes such as guaranteed purchase electricity for 20 years and a 30% incentive to make in addition to the base rate on equipment, on the one hand, increased foreign

investment in the renewable power plants after the international nuclear agreement (Barjam). Energy production by renewable sources increased; according to the Ministry of Energy, the share of renewable energy in the country's power plant capacity in April 2018 up to October 2018 increased from 0.5% to 0.8% [8].

## 2. Case study: Geographical location of Khoy city

The Khoy city is located in a vast plain surrounded by mountains. Khoy is situated 141 Km from Urmia (the centre of Azarbaijan province) and 143 Km from Tabriz, and it is 147 Km far from Makou. There are many mountains, lagoons, springs, and plains in Khoy. The city is located in a geographical position of 44 degrees and 28 minutes of longitude and 38 degrees and 56 minutes of latitude, and the difference between the time of Khoy city and Tehran is 25 minutes and 34 seconds, i.e. 12 noon of Khoy is 12:25 minutes and 34 seconds of Tehran [24].



Figure 2. Aerial map of Khoy.

## 3. Investigation of renewable energy potential in Khoy city

The first and foremost step in building a renewable energy plant in a region is to carefully examine the energy potential of that area and the feasibility of building a power plant in that area. It should be clear that what area has a good potential and, on the other hand, the infrastructures required

to harness that potential [11]. This essay tries to check the feasibility of wind, solar, biomass, and geo-thermal power station construction in the Khoy city using the screen software.

It uses the pvsyst software to examine the power plant connected to the photovoltaic network in the Khoy city on the other side.

### 3.1. Biomass

The primary purpose of evaluating the renewable resources is to find a more affordable place for energy consumption as one of the pioneers of this industry; the biomass energy goes back to the earliest periods of the history that used leaves and dry wood as fuel. Considering the rural population of the country, the distribution of rural communities and the cost of their connection to the national grid, on the one hand, and the lack of utilization of villages by the sanitary sewage system and environmental pollution.

The use of technology in rural-scale biogas has been the focus of attention for several decades.

The biomass sources that are suitable for energy production comprise a wide range of materials, which are mainly divided into six groups: 1. animal waste, 2. garbage, 3. urban wastewater, 4. forest and agricultural waste. 5.6. industrial organic waste and scrap [12], [13].

#### 3.1.1. Animal waste

The quality and quantity of livestock production vary depending on the type of feeding and the storage conditions. Therefore, the amount of produced gases per unit weight, and consequently, the amount of methane produced is also different. Therefore, in this work, considering the scientific resources available globally and the scientific ways for calculating the methane, the production coefficient from biomass sources is computed theoretically, and the biogas coefficient is derived from the animal waste [8].

We can use the Louisiana executive method to calculate the number of waste products from each animal. The results of accurate data and equation calculations are obtained to collect the waste mass-produced by each type of animal.

$$Q_{vsi} = N * T_{AMi} * V_i \quad (1)$$

$Q_{vsi}$  = Total waste produced in one year in Kg,  
 $T_{AMi}$  = Livestock weight in Kg,  $N$  = Number of livestock, and  $V_i$  = Waste production coefficient per livestock weight in the table above.

Therefore, the total animal waste produced in the West-Azərbayjan province in a year is 878473881 by sheep and 342877320 by cows. As a result, the volume of biogas produced from the cow's waste in the area is about 90 million and from sheep is about 200 million. Of course, this must require the mechanization of livestock and the creation of suitable infrastructure for the utilization of animal waste biogas that costs a considerable amount of money [14].

#### 3.1.2. Municipal waste (urban waste)

One of the issues of the today's urban life is a municipal waste. The health and the economic losses resulting from the improper control of waste in the Khoy town and the increasing waste production have given the city a non-standard and annoying form. The waste production is increasing in the Khoy city due to the changing consumption patterns and improving social welfare. Unfortunately, there has been no significant improvement, like the culture and the waste recycling infrastructure [8]. In Khoy, 100 tons of waste is produced daily, with the average amount of municipal solid waste per capita being corrosive materials = 73, paper = 7, plastic and rubber = 10, textiles = 10, glass and metals = 1 for each, and etcetera are 5%. In Iran, according to the quality of municipal waste in which productivity and fertilization are high, investment in the construction of incinerators is not recommended due to the abundance of wasteland around the towns that is suitable for landfill [16].

On the other hand, there are several problems with building a waste incinerator: at first, due to the high percentage of biological and wet materials in municipal waste in Iran, which drastically lowers its thermal value (4 to 5 MJ/Kg) compared to municipal waste in Paris and the suburbs (10 MJ/Kg and more). This issue and the humidity content of municipal waste (60%) cause the debris never to reach its combustion stage and needs auxiliary fossil fuel [16].

#### 3.1.3 RETscreen software

We considered a 550 kW biogas turbine power plant in the application with the initial costs considered near 473821 dollars with an inflation rate of 12%, in which the following diagram was obtained.

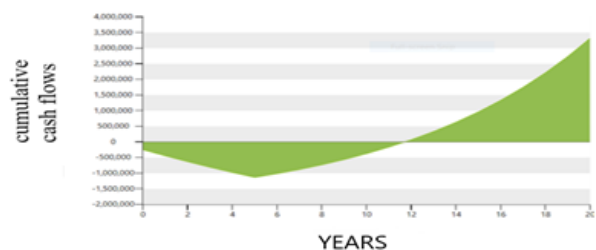

Figure 3. Cumulative cash flows.

According to the diagram above, which Retscreen obtained, the return on a fund of the biomass power plant in Khoy is about eight years than the other renewable power plants. The result is average (not good, not bad) but as mentioned at the beginning of the discussion, the plant's

infrastructure faces many problems, and is unlikely to be built in the next few years.

### 3.2. Wind energy

There are two main and practical factors to produce electricity by the wind energy. First, the intensity of the wind speed on different days of the year. Secondly, regularity and lack of fluctuation in the wind speed on different days of the year. Since the wind energy potential is proportional to the wind speed's third power, it is essential to select the locations where the average annual wind speed is as high as possible, and continuous winds frequently occur during the peak electricity consumption. In order to calculate the value of using wind in the energy consumption system, we also need to know the time dependence of the wind regime. The ongoing and constant winds, daily variations, and wind source turbulence can have the same importance as the average annual wind speed [11].

#### 3.2.1 RETScreen software

Due to the result of the RETSCREEN software, the average annual wind speed is 1.2 m/s in the Khoy city that is far below the country's average and the criteria for building a wind power plant. Hence, it seems impossible for constructing a wind power plant in Khoy; the software provides a 660 kW wind power plant with a projected inflation rate of 12% and a project life of 20 years. The project's initial investment is estimated at 710732 dollars, and the cost of maintaining the plant also covers 1% of the total cost. One of the most influential factors in attracting the investors is the return on investment; the rate of return on investment in Khoy is nine years old.

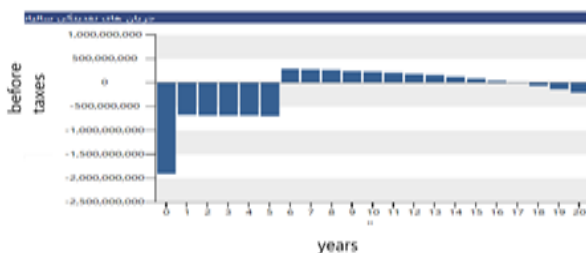

Figure 4. Annual cumulative cash flow.

#### 3.2.2. Effect of dust on wind turbines

The effect of dust on the wind turbine power should be considered in two respects: first, it increases the air density and viscosity by increasing environmental pollution including powder and lifts, thereby increasing the turbine blade performance.

The dirt accumulates on its blades, and this pollutant can be the insects, sand, dust, and rain polluters. These contaminants increase the roughness of the turbine blades; as the blade surface roughness increases, the turbine power loss increases, which is due to the increased flow separation on the blade profile [17]. The border with Iraq has caused heavy winds every year. Dust masses in this country have invaded the West Azerbaijan province, and caused reducing the air quality of the area, thus affecting the wind turbines.

### 3.3. Solar power

In the remainder of this work, we try to investigate the possibility of using the solar energy in the Khoy city.

According to the climatic data, the average amount of solar radiation emitted in Khoy is 4.6 KWh per square meters; an average is 4.5 to 5.5 in the country's average radiation.

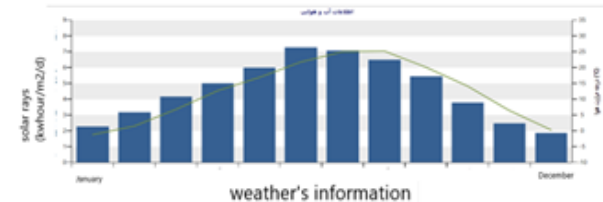

Figure 5. Weather information in Khoy.

Based on the information diagram, it can be concluded that the cost of operating the wind power plants is more minor than that for the photovoltaic power plants. Still, according to the following diagram, it can be stated that the initial cost of the wind power plant is much higher than the photovoltaic power plant since the cost of buying a solar panel for a photovoltaic power plant is much less than producing or buying wind turbines. The other point here is the cost of installing any wind power plant, which costs a higher price than the photovoltaic power plant [17].

The angle of sunlight and the number of hours of sunshine are essential in the construction and location of a power plant, and they have a significant impact on the power generation. The sunlight must be perpendicular to the panel in order to maximize the efficiency. Since the ray is not always vertical, in most cases, the panel should be at an angle that the sunlight is perpendicular to the panel. According to the result of the pvsyst software in which a power plant was connected to the 30 MW grid intended, the following results were obtained.

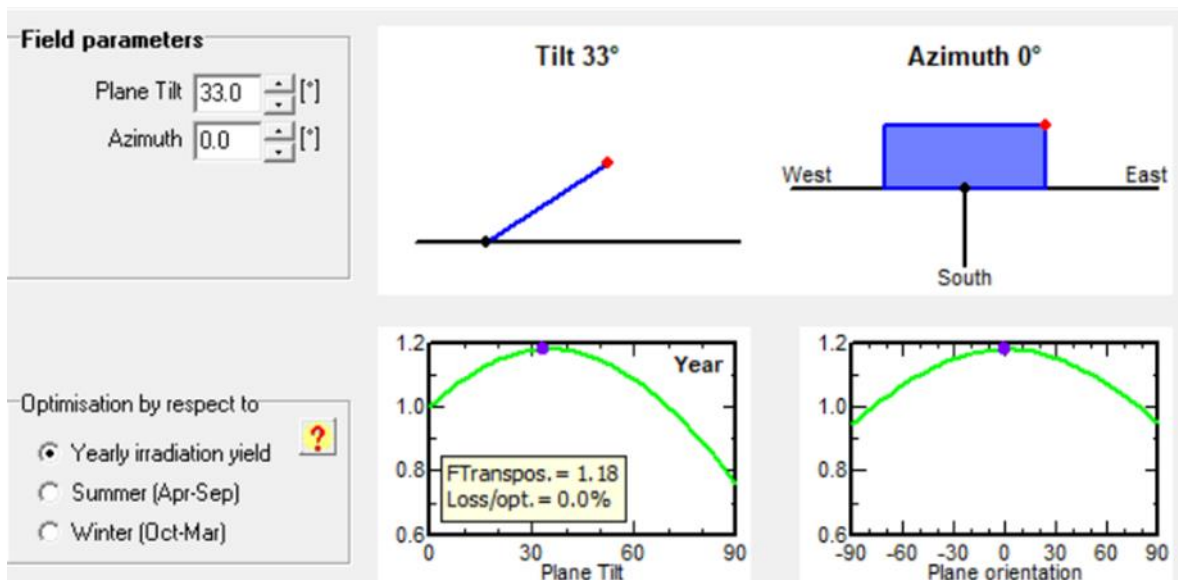

Figure 6. Field parameters.

Another thing to notice is the reliability of energy. Unlike the solar energy, which is available only during the day, the wind energy can be available during the day as well as the night, and this is one of the advantages of using the wind energy against the solar energy [14].

Now, using the RERscreen software, the 30 MW photovoltaic power plant with a lifetime of 20 years was considered in Khoy, and due to this, the following results were obtained. The inflation rate was assumed to be 12% and the risk of the project obtained through the software was 10%. Although

the photovoltaic power plants have a higher production cost than the fossil fuels, they are an excellent service to the environment and to protect the next generation.

Economically, the project will be profitable in a few years, with a 25-year return on investment and a 25% internal rate of return. The initial cost of the solar power plant in Khoy is based on the screen using the Suntech panels; each panel has a 260 W power, and is equipped with a single-axis detector, considered to be \$40 million. The cost of maintaining and operating is 1% of the total cost.

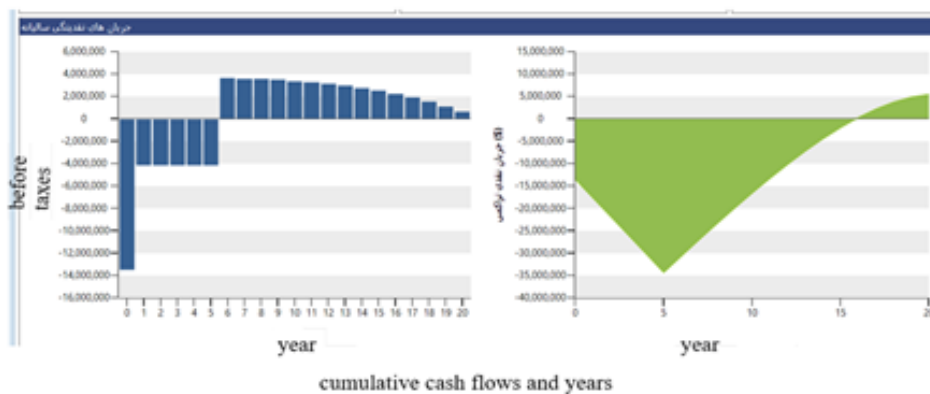

Figure 7. Cumulative cash flows.

### 3.3.1. Effect of dust on photovoltaic panels

Dust sits on the solar panels and causes reduction of absorption and reflection of light; on the other hand, the efficiency of solar panels is a function of the intensity of the light received. The air filter coefficient is one of the significant factors on the light intensity of the panels; the presence of dust in the air reduces this coefficient, and thereby reduces the efficiency of the panels. Therefore, considering this issue for constructing a solar

power plant is essential. As a result, the Khoy city, which has been affected by the inundations from abroad during the seasons of the year also faces a decline in the panel efficiency.

### 3.3.2. Result of pvsyst software

For constructing a 30 Mgw photovoltaic power plant, fixed panels were considered with the following information.

**Table 1. Pv module summary.**

PV module	Sizing voltages
230wp25 vSTP230-20/wd since 2013 suntech Europe20	vmpp 25.0 v
	voc 41.4 v

There are three ways to determine the optimum angle of the panels in pvsyst based on what time of year the optimization takes place. These three

types are optimization based on annual, winter, and summer radiation intensity. Thus using the average of the yearly radiation intensity, the angle required to install the panels was obtained. As mentioned at the beginning of the discussion, it is nearly 33 degrees. The following is a diagram overview of the system used.

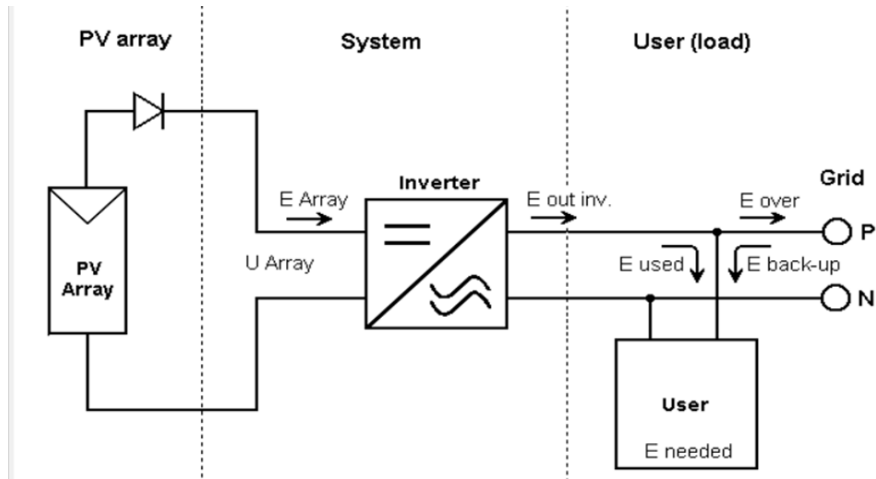

**Figure 8. System review.**

The photovoltaic panels must be placed in 10 series between 7 and 12 in order to generate the 30 MW of electricity required. The power plants do not often consume electricity themselves but sell it to the grid and derive the required heat. Due to the annual yield of this project, which is 58798, and by taking this point, according to the Satba contract, it buys the electricity generated by a renewable solar power of 1\$kilowatt-hour; this power plant can earn 1.6 million dollars from the sale of the generated electricity.

Constructing a 30 MW power plant based on the software and according to the selected photovoltaic panel requiring a 212194 m space and the capacities of the solar panels and the number of panels, the inverters were required to show the following.

Global system summary			
Nb. of modules	130430	Nominal PV Power	29999 kWp
Module area	212194 m <sup>2</sup>	Maximum PV Power	29526 kW/dc
Nb. of inverters	18567	Nominal AC Power	24137 kW/ac

**Figure 9. Global system summary.**

### 3.3. Geo-thermal energy

Since the beginning of the industrial era, the world's population has grown from a few hundred million to seven billion. On the one hand, an increase in the population and an increase in the social welfare require energy. The growing need for power has led to more and more people using

fossil fuels. However, restrictions on the use of fossil fuels due to their non-renewable nature and pollution that has warmed the planet and disrupted the natural ecosystem have limited the use of these energy sources. The geo-thermal energy is generated by the decomposition of radioactive elements and a high pressure from gravity. Experience has shown that the higher the depth of the earth, the higher the temperature. Approximately 3 degrees Celsius is added to the earth's temperature for about 111 m. The temperature in the lower layers of the earth's crust is about 1,300 degrees, and in the earth's core is about 5,000 degrees. It is not possible to extract the heat directly from the earth, and to do this, there must be a transfer fluid to transfer heat to the earth's surface [20].

#### 3.3.1. Appropriate locations for geo-thermal energy utilization

The areas with hot springs and volcanic mountains are the first areas where the geo-thermal energy can be exploited. In general, the geo-thermal energy can form in areas where the geological processes have areas with hot springs, and the volcanic mountains are the first areas where the geo-thermal energy can be exploited.

In general, the geothermal energy can form in areas where the geological processes have allowed magma and lava to flow to approach the surface. Magma usually approaches three parts close to the

earth's surface: 1- Location of continental and oceanic plates 2- Expansion Centers: areas where the continental plates intersect 3- Hot spots: points that continuously send magma from the mantle to the surface [21].

The Khoy's geo-thermal area is 35 km from Khoy in the Qatar Valley. The climate in this region is temperate to cold. According to the geo-thermal exploration reports made in 1975 to 1978 in a contract between the Ministry of Energy and the Italian company, this region was prone to the geothermal energy for further study. The Dare Khan Trust rift is the most critical fault and fraction in the area, which also plays a vital role in the emergence of the hottest hot springs in the area. The mentioned fault has an almost east-west extension and a slope to the north. Geo-chemistry is an essential geo-thermal resource exploration tool used to estimate the geo-thermal reservoirs' temperature and chemistry fluid and the origin of the geo-thermal waters. Based on the deposition of travertine and iron oxides in the hot springs area, these waters are saturated with calcite and iron oxide. In terms of gas composition, the mass of the gas in the spring is CO<sub>2</sub>. All of this evidence demonstrates or represents the region's potential for the geo-thermal energy [22].

### 3.3.2. Choosing type of geo-thermal energy utilization in Khoy city

Using the geo-thermal energy is divided into the direct and indirect parts.

The direct geo-thermal applications include the heat pumps, snowmelt, aquaculture, agricultural and greenhouse applications, and heating and cooling of buildings, and its indirect uses are limited to generating electricity at the power plants. The type of operation depends on the type of geo-thermal resource. Generally, the geo-thermal sources are divided into five groups: hot water sources, dry steam, pressurized, hot boulders, and melt [21].

In Khoy, the temperature tanks are between 90 and 120 degrees, and a maximum of 145 degrees is estimated from the type of hot springs [22]. Therefore, the hot water sources are divided into three: 1) A high temperature- 150 °C is suitable for generating electricity in regular power plants 2) A temperature between 100 to 150 degrees is ideal for power generation in advanced binary power plants 3) A temperature below 100 degrees is ideal for direct use. Due to the temperature of the tanks in Khoy, the geo-thermal energy can be used either directly or generate electricity in

advance for the binary and dual-circuit power plants.

### 3.3.3. Economic costs of building a power plant in Khoy

The cost of development operations in a geo-thermal field includes the cost of surface exploration, cost of determining the installation proving the reservoir's capacity, cost of constructing the main power plant and ancillary facilities. In a general classification, the economic parameters affecting the cost of generating electricity include the upward costs of geo-thermal field development, initial investment costs, and operating and maintenance costs [23].

According to the calculations based on the cost tables for the two-circuit geothermal energy cycles in the Khoy city in West Azerbaijan province and fluid flow, the initial capital for the construction of a 5 MW power plant in Khoy is estimated at \$11 million, as well as the cost. The plant's operation and maintenance are estimated at \$550,000.

With the introduction of high results in the Retscreen software, taking into account the 12% inflation rate and the 20-year lifespan of the project, the return on the investment period of this project is predicted to be 12 years.

## 4. Results and discussion

**Table 2. Summary of software results and calculations.**

	Capacity of power plant	Period of return on investment	Annual income (dollars)
Wind power plant	660 KW	9 years	78970.2
Solar power plant	30 MW	25 years	1.6 million
Geo-thermal power plant	5 MW	12 yeras	916666.6
Biomass power plant	550 KW	8 years	59227.6

**Table 3. Summary of software results.**

	For every kilowatt of electricity produced	Costs (dollar)
Wind power plant	1 kw	1076.86
Solar power plant	1 kw	1333.3
Geothermal power plant	1 kw	2200
Biomass power plant	1 kw	861.49



## 5. Conclusion

The Khoy city has a relatively low potential for renewable energy, especially wind. Considering that the inflation rate in the software was equal to 12% and the interest rate of the project loan was supposed to be 4%, the initial capital for the construction of a 660 kW wind power plant in Khoy was expected to be equal to 710732 dollars. The initial capital for the development of the 30-megawatt photovoltaic plant was estimated at \$40 million, with a return on investment of 25 years and a 25% operating rate. The initial capital construction of the 550-kilowatt biomass power plant was estimated at 473821 dollars, with a return period of 8 years. The initial capital for the development of a 5 M binary and dual-stage geothermal power plant was expected to be \$11 million, with a return period of 12 years and a fluid flow rate of 140 kWh for 1 kW electricity. As a result, the construction of a solar power plant in Khoy should be prioritized, as well as the development of a binary geo-thermal power plant, as well as the direct use of geo-thermal energy for the snowmelt and greenhouse applications. Due to the results of the pvsyst software, which considers a connected power plant, the level of horizontal irradiation is 4.6pSh per day, and 212194 m of land is required to construct the 30 MW power plant. The amount of electricity generated by the power plant is 1.6 million dollars in a year for the power plant. The photovoltaic panels should be arranged in 10 series between 7 and 12 in order to avoid shadowing. Based on the results of the RETScreen software, Khoy does not have a high potential in the wind energy, and the biomass and construction of these power plants in the city are not economically feasible. In terms of dust, the town is dust-free for most months of the year unless dust enters the soil from the neighbouring countries, which reduces the efficiency of the photovoltaic panels and increases the maintenance costs. However, it will not affect the wind turbines since its positive and negative impacts affect each other.

## 6. References

- [1] Sorrell, S. (2015). Reducing energy demand: a review of issues, challenges, and approaches (1st Ed., pp. 74-82). Renewable and Sustainable Energy Reviews.
- [2] Pachauri R, Reisinger A, editors. Climate change 2007: synthesis report. Contribution of working groups I, II, and III to the fourth assessment report of the inter-governmental panel on climate change. Geneva, Switzerland; IPCC; 2007.
- [3] Models and tools (n.d.). Retrieved June 15, 2016, from: [http://www.nrel.gov/analysis/models\\_tools.html](http://www.nrel.gov/analysis/models_tools.html).
- [4] "Difference between simulation and optimization- Research Papers-1556 Words." StudyMode. N.p., n.d. Web., 16 June 2016.
- [5] Gifford, J. S., Grace, R. C., and Rickerson, W. H. (2011, May). Renewable energy cost modeling: a toolkit for establishing cost-based incentives in the united states [PDF]. U.S. Department of Energy.
- [6] SAM help (n.d.). Retrieved June 16, 2016, from: [https://www.nrel.gov/analysis/sam/help/html-php/index.html?climate\\_solar.htm](https://www.nrel.gov/analysis/sam/help/html-php/index.html?climate_solar.htm).
- [7] Blair, N. (2014). System advisor model, SAM 2014.1.14: general description. Golden, Colorado: National Renewable Energy Laboratory, February 2014.
- [8] Nourollahi, Younes, Mehran Ghalamchi, Mehdi Kheirvarz, and Bahare Ansari (1392), Potential and Evaluation of Biogas Production Capacity of Biomass Energy Sources in Iran, 3rd Iranian Conference on Renewable Energy and Scattered Production, Isfahan, University of Isfahan, [https://www.civilica.com/Paper-ICREDG03-ICREDG03\\_037.html](https://www.civilica.com/Paper-ICREDG03-ICREDG03_037.html).
- [9] Dr. Khosro Afzalian (Assistant Professor of Mashhad Azad University of Architecture and Urban Development) and Siamak Hasanzade Rad (Master of Architecture Engineering, Islamic Azad University of Mashhad). Reconstruction and reuse with a green and sustainable approach to contemporary Iranian residential architecture.
- [10] Ministry of Energy, [www.moe.gov.ir](http://www.moe.gov.ir).
- [11] Ghasem Hasani, Feasibility of wind energy and its application in wind turbine installation potential. Case Study of Sistan and Baluchestan-Zabol Province.
- [12] Nabi Bidhendi, Gholamreza and Nima Javidi, Investigating the main types of biomass resources in Iran by their energy production approach (1396), 4th International Conference on environmental planning and management, Tehran, Faculty of Environment, University of Tehran, [https://www.civilica.com/Paper-ESPME04-ESPME04\\_453.html](https://www.civilica.com/Paper-ESPME04-ESPME04_453.html).
- [13] Babel, S., Pecharaply, A., and Sae-Tang, J. (2009). Anaerobic codigestion of sewage and brewery sludge for biogas production and land application. Int. J. Environ. Sci. Tech., 6 (1), 131-140 (10 pages).
- [14] Country Statistics Organization, [www.amar.org.ir](http://www.amar.org.ir).
- [15] Khamr, Gholamali, Banafshe Harati, and Banafshe Shahraki Nia, Manage and organize waste collection and recycling in environmental protection, case study of Zabol province (1394), The first electronically national conference on the natural environment, Institute of Environment, Jahad Daneshgahi, [https://www.civilica.com/Paper-NECONF01-NECONF01\\_100.html](https://www.civilica.com/Paper-NECONF01-NECONF01_100.html).

- [16] Javad Nasiri, Feasibility Study of Saveh Biogas Power Plant, Iranian New Energy (1385).
- [17] Majid Zandi, Roghaye Gogsazi Ghochani, Rouhollah Shabani Nezhad, and Mahyar Mirzaei Omrani, Climate of Iran Considering Technical and Economic Parameters (2017).
- [18] Potential Assessment of the Construction of Photovoltaic Solar Power Plants in the South-East Wind caused by abrasion and roughness in the blades, the first conference on wind and solar energy.
- [19] Ramin Mehri and Mohsen Kalantar, Design and simulation of photovoltaic system for Hamadan city.
- [20] Jalil Naji, Nastaran Ahmadi Masoud, Meysam Ghadami, and Ali Amjadi, Geo-thermal energy and its future prospects in Iran.
- [21] Seyed Abolfazl Mir Ashrafi, Mojtaba Moata, and Hasan Moghbeli, Geo-thermal energy of Mahallat.
- [22] Nastaran Hojati, Investigation of geo-thermal energy potential in Khoy, Ghatour Dare, Iranian New Energy Organization.
- [23] Khalil Monfareedi and Behnam Mousa Zade Khezrabad, Estimating Power.
- [24] Taghilou, Masoumeh, 2016, Study of natural geography and climatology of Khoy city, the third scientific research conference of new horizons in geography and architectural planning and urban planning of Iran, Tehran, <https://civilica.com/doc/505237>.
- [25] F. Salek and M. Rahnama, 2021, Investigation of Solar-Driven Hydroxy Gas Production System performance Integrated with Photovoltaic Panels with Single-Axis Tracking System, [http://rera.shahroodut.ac.ir/article\\_2088.html](http://rera.shahroodut.ac.ir/article_2088.html).
- [26] S. Yerel Kandemir M. Ozgur Yayli, and Emin Acikkalp, Assessment of Electric Energy Generation and Installed Power Capacity in Turkey. <http://dx.doi.org/10.22044/rera.2021.10940.1061>.
- [27] Rostami r and khoshnava s, limit, 2016, An overview of Afghanistan's trends toward renewable and sustainable energies, <https://doi.org/10.1016/j.rser.2016.11.172>.
- [28] Vreenegoor, R., Hensen, J., and de Vries, B. (2008). Review of existing energy performance calculation methods for district use (1st Ed., pp. 1-8). Netherlands. Retrieved from: [http://www.janhensen.nl/publications\\_folder/08\\_ibpsa-nvl\\_vreenegoor.pdf2](http://www.janhensen.nl/publications_folder/08_ibpsa-nvl_vreenegoor.pdf2).
- [29] Kandt, A., Burman, K., and Simpkins, T. (2010). Solar 2010: comparative analysis of solar mapping tools (1st Ed.). Retrieved from: <http://www.nrel.gov/docs/legosti/old/47638.pdf>.
- [30] Lalwani, Mahendra, Kothari, D.P., and Singh, Mool. (2010). Investigation of Solar Photovoltaic Simulation Softwares. International Journal of Applied Engineering Research. 1.