

# Experimental Investigation on a Ducted Savonius Vertical Axis Wind Turbine and its Performance Comparison with and without End-plates

N. Mishra<sup>1\*</sup>, A. Jain<sup>1</sup>, A. Nair<sup>1</sup>, B. Khanna<sup>1</sup> and S. Mitra<sup>1</sup>

*1. Mechanical Engineering Department, School of Engineering, Shiv Nadar University, Gautam Buddha Nagar, India*

Receive Date 04 June 2019; Revised 25 June 2019; Accepted Date 25 June 2019

\*Corresponding author: [mishra.nishantmishra@gmail.com](mailto:mishra.nishantmishra@gmail.com) (N. Mishra)

## Abstract

As the energy demand is growing and fossil fuel-based energy resources are getting depleted, there has been an increased focus on the use of renewable energy resources. Wind energy is a highly suitable energy resource that can be harvested for this purpose. This research work deals with the design and fabrication of novel designs as a mean to harness wind energy using a 'Savonius' Turbine. It is generally employed to harvest the low to very low wind speed potentials. This paper introduces a novel concept about a Ducted Savonius wind turbine, where power generation can increase more than 10 folds. The paper provides experimental validation of the effect of using a converging ducted structure with single-stage and double-stage configurations of a Savonius wind turbine. The paper also compares the turbine's performance with and without end-plates and compares Single-Stage and Double-Stage Turbines. The experimental results obtained show around 15% increase in the tangential blade velocity in a single-stage rotor when endplates are used. The results of the study prove that power coefficient increases with the addition of a converging ducted structure with the Savonius wind turbine, and also with the use of end-plates.

**Keywords:** *Savonius Turbine, Vertical Axis Wind Turbine, End-plates, Duct.*

## 1. Introduction

The world has become warmer over the past few decades, major reason being the emission of greenhouse gases from the thermal energy sector [1, 2], thus necessitating newer avenues of renewable energy. One such renewable energy resource worth being harvested is Wind Energy. From pumping water in China using Horizontal Axis Wind Turbines (HAWTs) to grinding grain in Iran and the Middle East using Vertical Axis Wind Turbines (VAWTs), wind energy has been an answer to the undying requirements of man for a long time now. The potential of wind is an unevenly distributed commodity in the world. The Northern and Western parts of India experience much higher wind speeds than the south-western part of India [3]. As a consequence, the conventional wind turbines cannot be installed everywhere. The relatively unexplored Vertical Axis Wind Turbines could prove to be very useful to bridge the energy crisis in such regions. However, the question arises that if we are able to exploit the low wind potential, can we use it everywhere? This is where the unconventional wind turbines come into play.

HAWTs are the most common types of wind turbines built across the world to tap potential from high wind velocities. VAWT (Vertical Axis Wind Turbine) has two or more blades, and the main rotor shaft runs vertically. Ryoichi S. Amano [4] and Ashwani K Gupta [5] have explained in detail the research work carried out on Vertical Axis Wind Turbines in the current century. Nur Alom and Ujjwal K. Saha did a compilation on the research into the augmentation techniques of a Savonius turbine in the last forty years [6]. A Savonius Turbine is a VAWT, resembling a cup anemometer, as shown in figure 1 below, in its design and working.

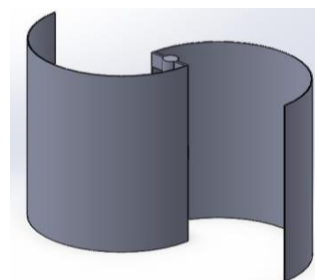

Figure 1. CAD model of a Savonius Turbine.

It has many advantages over other turbines because its construction is simpler and cheaper. It rotates in a fixed direction regardless of the flow of wind direction, and has a good starting torque at lower wind speeds. The performance of the Savonius rotor has been studied by many researchers to determine the optimum design parameters of this rotor. Michele Mari *et al.* proposed a novel geometry for VAWT based on the Savonius concept [7] because of its ability to tap wind energy at low wind speeds. N.H. Mahmoud *et al.* [8] concluded that a two-blade rotor is more efficient than the three and four ones. They also concluded that the rotor with end-plates gave a higher efficiency than those without end-plates, while the blade aspect and overlap ratio were studied by Alexander *et al.* [9]. Taking inputs from our literature study, an effort is made here to experimentally compare the results obtained for Savonius turbine with and without end-plates.

A Savonius turbine can be a single-stage, double-stage, and a multi-stage turbine. Research works have been carried out in the past to test the performance based on the stages involved [10, 11]; however, not much open literature is available on testing based on the best overlap and aspect ratio. Based on the overlap and aspect ratios suggested for different stage rotors [12-14], experimental investigations were carried out in the present research works to compare the performance between a single- and a double-stage rotor Savonius turbine.

A converging duct increases the velocity of the wind. Ducted turbines, both HAWTs and VAWTs, have been tested earlier [15-17] by many researches and most of them have shown to

improve the performance of the turbine. Deriving ideas from the research works, a new concept of using a single re-aligning duct was introduced in the present research work.

This paper provides the experimental validation of the effect of using a converging ducted structure with single-stage and double-stage configurations of a Savonius wind turbine, and shows that power generation can increase more than 10 folds. In this work, we also compare the turbine's performance with and without end-plates and compare Single-Stage and Double-Stage Turbines. The experiment results obtained show around 15% increase in the tangential blade velocity in a single-stage rotor when end-plates are used.

Applications of such VAWTs can range from industrial buildings, railway tracks, roads, individual homes for a distributed generation, etc. Further, applications of nanofluidic thermosyphons in renewable energy systems can also be studied by the research work carried out by Mahdi Ramezanizadeh *et al.* [18-21].

## 2. Experimental Set-up

The experiment uses various models of the Savonius wind turbine with different configurations such as single-stage and double-stage turbines. These models were also tested in combination with a converging duct in the wind tunnel. The overlap and aspect ratios of single- and double-stage turbines were chosen according to the literature survey [8-11], and the details were mentioned for each one of the following cases.

The schematic diagram of the test rig used in the set-up is shown in figures. 2 (a) and (b) below.

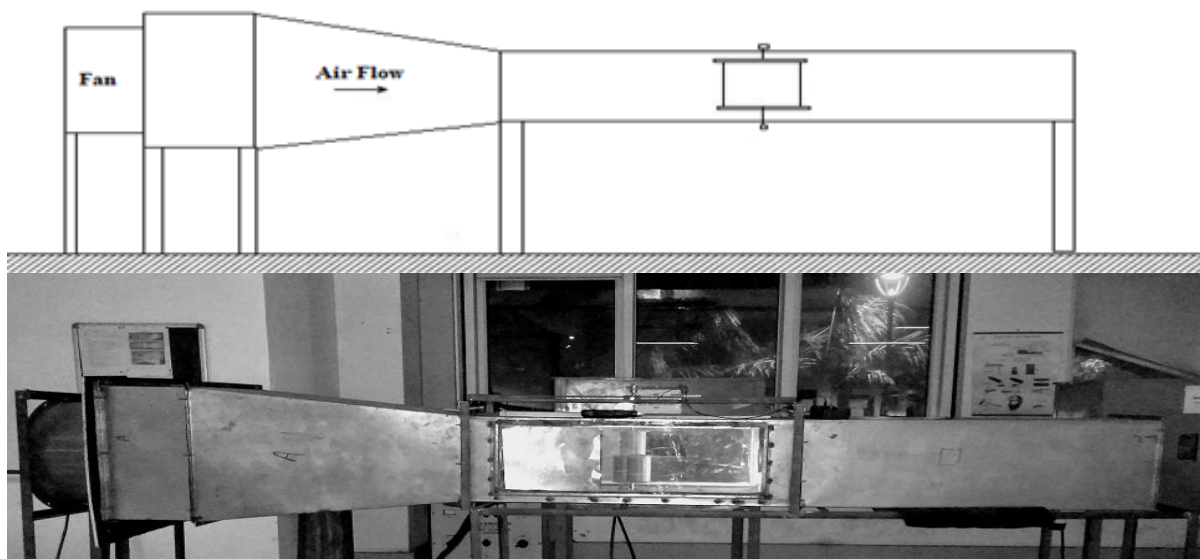

Figure 2. (a) Schematic representation of the test section (above) and (b) wind tunnel. (below).

All the different models of the Savonius turbines were placed in the test section of the wind tunnel and tested for their performance. An anemometer measures the velocity of the wind. The rotation of

the rotor was measured by a tachometer. Table 1 shows the range of measurements for all the measuring systems.

S. No.	Systems/Instruments used	Range	Accuracy
1.	Wind Tunnel	0.7 m/s–12 m/s	N/A
2.	Anemometer–HTC Model AVM-06	0.7 m/s–30 m/s	±(2.0% reading + 50 characters)
3.	Tachometer–Lutron DT2234C	0.1 RPM < 999 RPM	±( 0.05 % + 1 digit )
4.	Multimeter -HTC DM-81 Digital Multimeter	No. of counts-2000	N/A
5.	Autotransformer – Dimmerstat AEL India	0-415 V/0-470 V, 15 A	N/A

The experiments were conducted for comparison between two bladed–

- (i) Single-stage Savonius turbines-with and without end-plates.
- (ii) Single-stage and double-stage turbines, both with end-plates.
- (iii) Single-stage and double-stage turbines-with and without duct.

The wind speed ranging for all the above-mentioned testings was kept from 0.7 m/s to 6 m/s. This speed was taken in accordance with the design parameters, and considering the use of duct as higher wind speeds could have resulted in the breakage of the small scale model of the turbines made of plastic polymers. Also the primary motto

of this research work was to capture and test the performance of a Savonius turbine for low to very low wind speeds, which was otherwise not possible through any other wind turbine.

The design parameters of the different geometry configurations used in the investigations are described below.

**2.1. Case 1: Single-stage Savonius turbines-with and without end-plates**

The parameters for both rotors, as shown in figures. 3 (a) and (b), are as mentioned below:

Wing spread of rotor (D) = 7.6 cm

Height of blades/shaft (h) = 14.1 cm

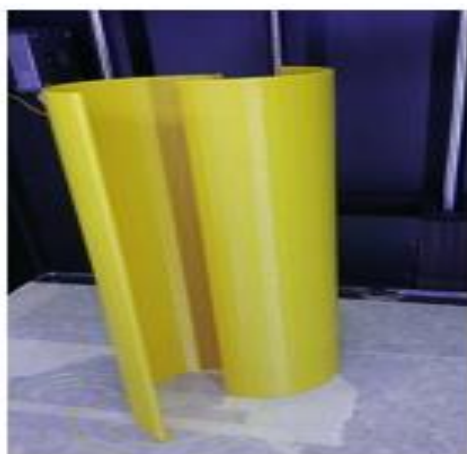

(a)



(b)

Figure 3. Single-Stage Turbine (a) without end-plates (b) with end-plates.

### 2.2. Case 2: Single-stage and double-stage turbines, both with end-plates

Parameters for a single-stage rotor, as shown in figure. 4 (a):

Wing spread of rotor ( $D$ ) = 15.5805 cm, Height of blades/shaft ( $h$ ) = 24 cm

Diameter of turbine blades ( $d$ ) = 8.5 cm, Spacing between blades ( $e$ ) = 1.4195 cm

Parameters for a double-stage rotor, as shown in figure. 4 (b):

Wing spread of rotor ( $D$ ) = 14.2545 cm, Height of blades/shaft ( $h$ ) = 24 cm

Diameter of turbine blades ( $d$ ) = 8.5 cm, Spacing between blades ( $e$ ) = 2.7455 cm

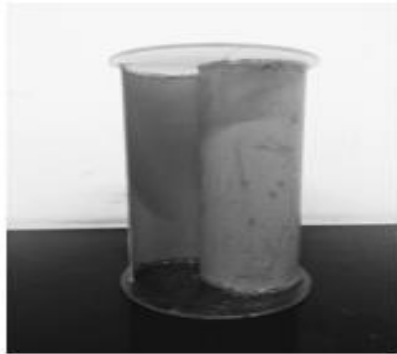

(a)



(b)

Figure 4. Savonius turbines with end-plates (a) single-stage (b) double-stage.

### 2.3. Case 3: Single-stage and double-stage turbines-with and without duct

Both the turbines mentioned above were also tested in combination with a converging duct, as described below. A converging duct would help increase the velocity of the incoming wind and

would direct it to the positive side of the blade, while not letting any incoming wind strike the negative blade, thereby, increase the speed and torque of the turbine. A concept of using a converging duct is shown below in figure. 5.

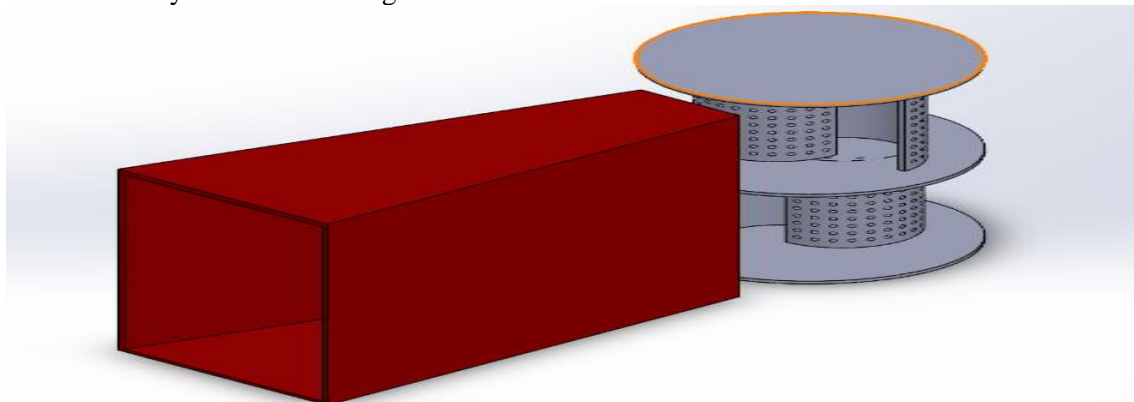

Figure 5. CAD model of the concept of using a converging duct with the Savonius rotor.

#### 2.3.1. Nozzle design

The following nozzle design was considered keeping in mind the size of the wind tunnel. The width at the entry of the nozzle is kept approximately of the same size of that of the wing spread of the rotor ( $D$ ). This was done to cover the exposed surface area of the negative side of the blade and to prevent the incoming wind striking the negative blade. The width at the exit is kept of the same size of that of the diameter of each blade. Figure. 6 below shows the converging duct used for the experiment.

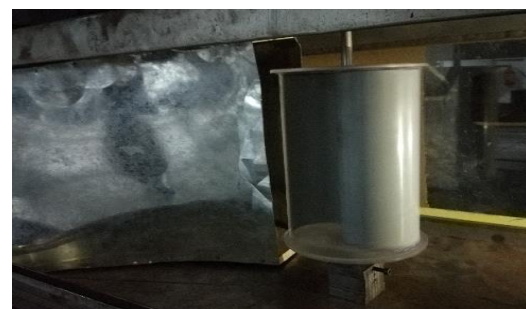

Figure 6. Turbine with a converging duct inside the wind tunnel.

### 3. Mathematical Formulations

Total amount of power P that is available in the wind is:

$$P_{\omega} = \frac{\rho \times A \times V^3}{2} \quad (1)$$

where:

$\rho$  = Density of the air  
 $A$  = Swept area of the turbine  
 $V$  = Wind speed

According to the Betz law, no wind turbine can convert more than 59.3% of the kinetic energy of the wind. The power coefficient,  $C_p$ , is defined as the ratio of the total power output  $P_o$  by a wind turbine with the total power  $P_{\omega}$  available to the wind turbine.

$$C_p = \frac{P_o}{P_{\omega}} \quad C_{p,max} = 0.59 \quad (2)$$

The theoretical maximum power efficiency of any design of wind turbine is 0.59 (i.e. no more than 59% of the energy carried by the wind can be extracted by a wind turbine). The  $C_p$  value is unique for each set-up and depends on the wind turbine's strength and durability as well as the surrounding conditions like air density and turbulence, due to which  $C_p$  comes out to be much lower than 0.59 and incorporating other engineering systems that are used in a wind turbine set-up like gearbox, generator, bearings, the efficiency gets further reduced.  $C_p$  represents only the aerodynamic efficiency of the wind turbine, and thus takes losses due to turbulence and other environmental conditions as well as turbine's physical properties into account and not the mechanical losses [22]. Therefore,  $P_o$  converted from the wind into rotational energy in the turbine can be found from the following equation:

$$P_o = \frac{\rho \times C_p \times A \times V^3}{2} \quad (3)$$

$C_p$  depends on how the turbine behaves in a particular condition, i.e. for different rotational speeds of turbine,  $C_p$  is different. This implies that  $C_p$  is a function of the Tip Speed Ratio (TSR)  $\lambda$ , which is defined as:

$$\lambda = \frac{TipSpeedoftheBlade}{WindSpeed} \quad (4)$$

$$\lambda = \frac{(\omega \times R)}{V} \quad (5)$$

The output power  $P_o$  is found experimentally,

$$P_o = T \times \omega \quad (6)$$

Here,

$T$  = mechanical torque,  $\omega$  = angular velocity of the rotor blades

$$\omega = \frac{2\pi N}{60}$$

Here,

$\omega$  = rotational velocity of the turbine,  $R$  = turbine radius,  $V$  = wind speed

### 4. Results and Discussion

The following graphs show the relations obtained using the turbine with different configurations between various parameters for single-stage, double-stage, and ducted turbines. The power here was measured with the help of dynamo and taking a load resistor of 50 ohm. The torque was calculated with the help of power using the relation mentioned in Equation 6, while the wind speed was calculated with the help of an anemometer.

#### 4.1. Case 1: Comparison between single-stage rotors with and without end-plates

The following data was recorded during the experiments.

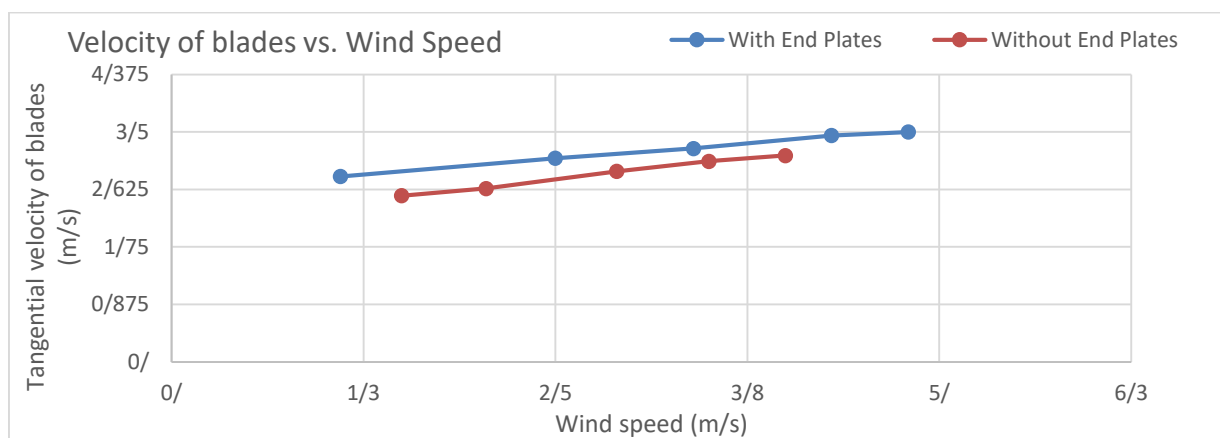

Figure 7. Variation in Velocity of Blades with Wind Speed for single-stage rotor with and without endplates.



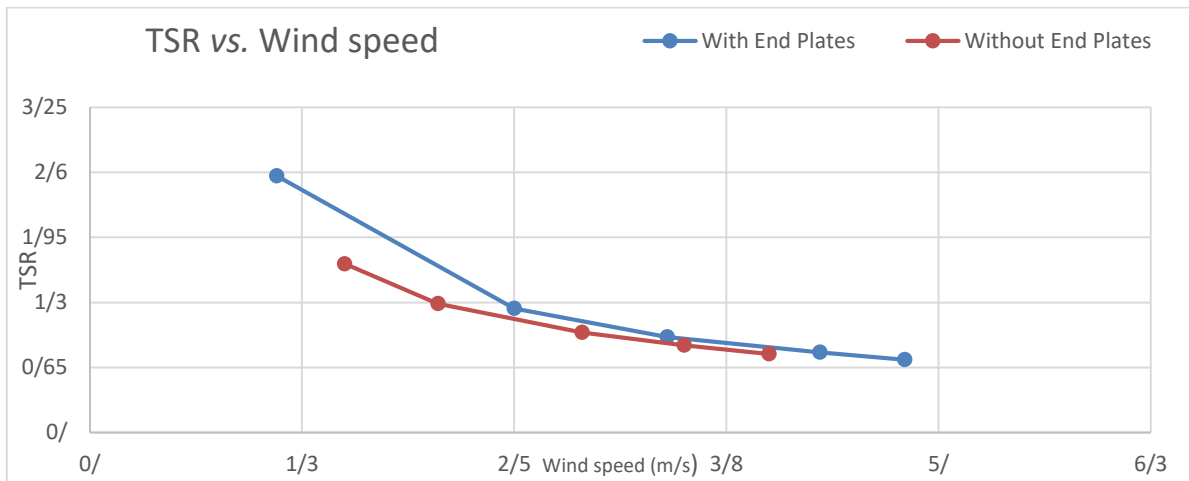

Figure 8. Variation in TSR vs. Wind Speed for single-stage rotor with and without end-plates.

It can be seen in figures. 7 and 8 that the turbines with end-plates have performed better. A higher velocity of blades and TSR is obtained in cases with rotors with end-plates. This happens as the end-plates arrest the movement of air outside the rotor area, and the wind energy incident on the blades is completely used by the turbine.

#### 4.2. Case 2: Comparison between single-stage and double-stage rotors

The following data was recorded during the experiments.

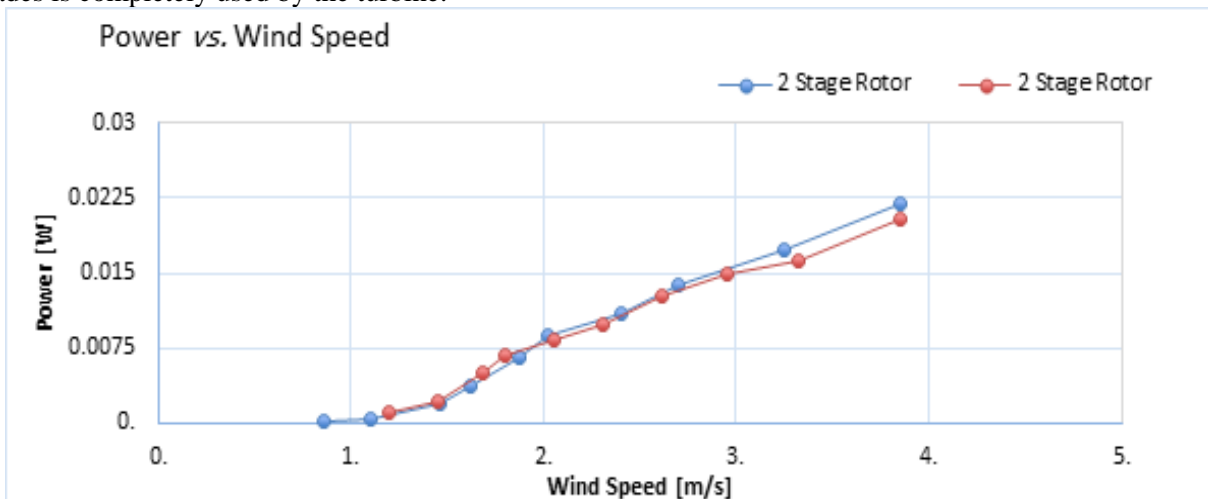

Figure 9. Variation in power with wind speed for single- and double-stage rotors.

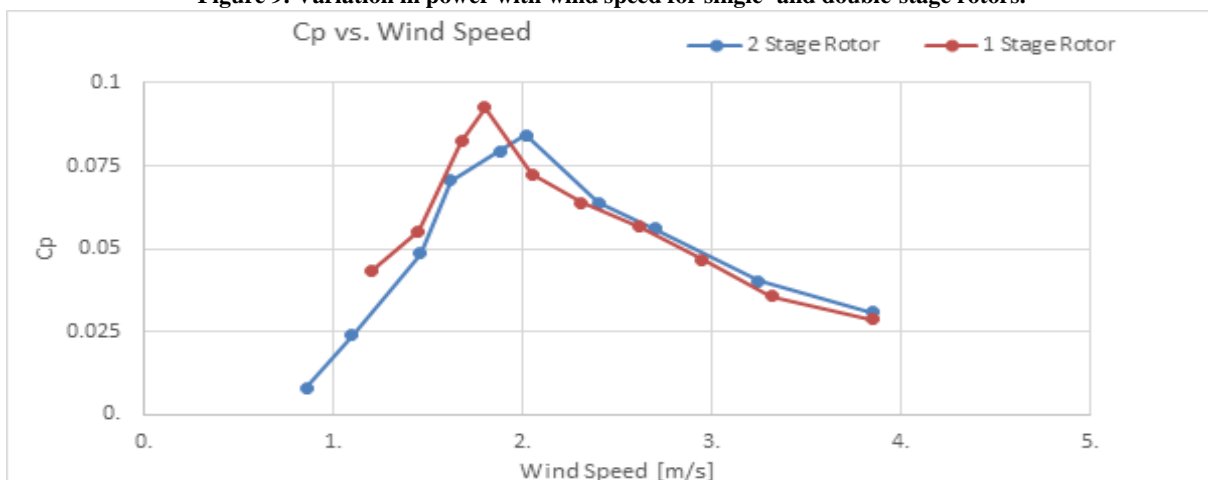

Figure 10. Variation in Cp with wind speed for single- and double-stage rotors.

It can be observed in figures. 9 and 10 that a single-stage rotor performs better at lower wind speed ranges (<~2 m/s), and the double-stage turbines take over at relatively higher wind speed ranges. It is for the same reason that none of the turbine rotor configurations are ruled out for future experiments. Both the configurations were tested. Depending upon the usage and requirement, average wind

speed of a region, a suitable configuration can be used.

**4.3. Case 3: Comparison between single-stage and double-stage rotors-with and without duct**

The following data was recorded during the experiments.

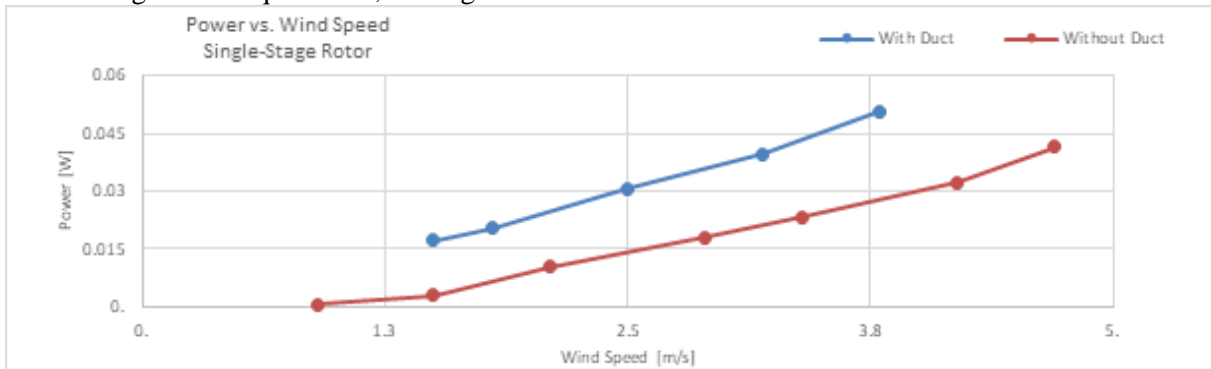

Figure 11. Variation in power with wind speed for single-stage rotor using duct.

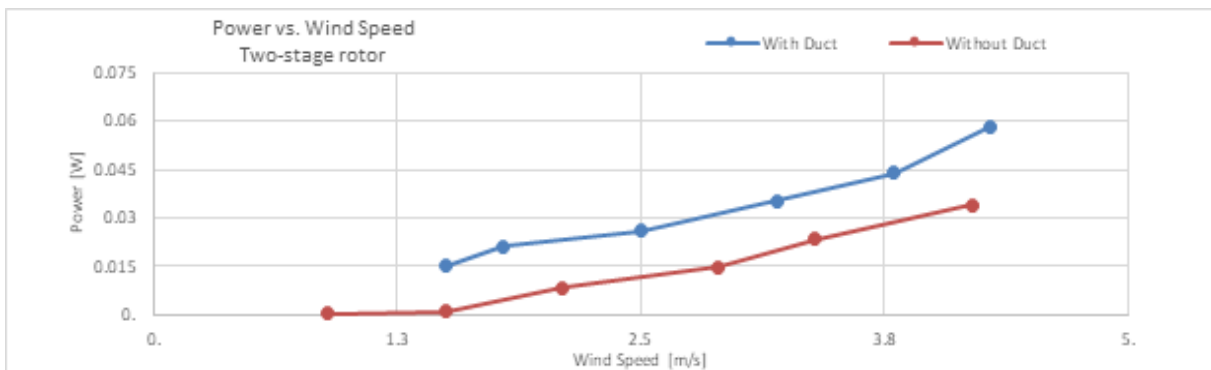

Figure 12. Variation in power with wind speed for two-stage rotor using duct.

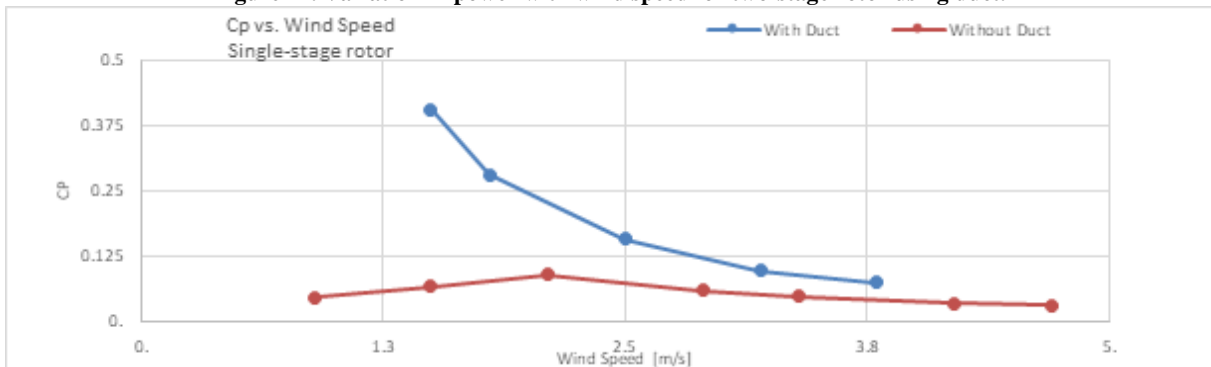

Figure 13. Variation in Cp with wind speed for single-stage rotor using duct.

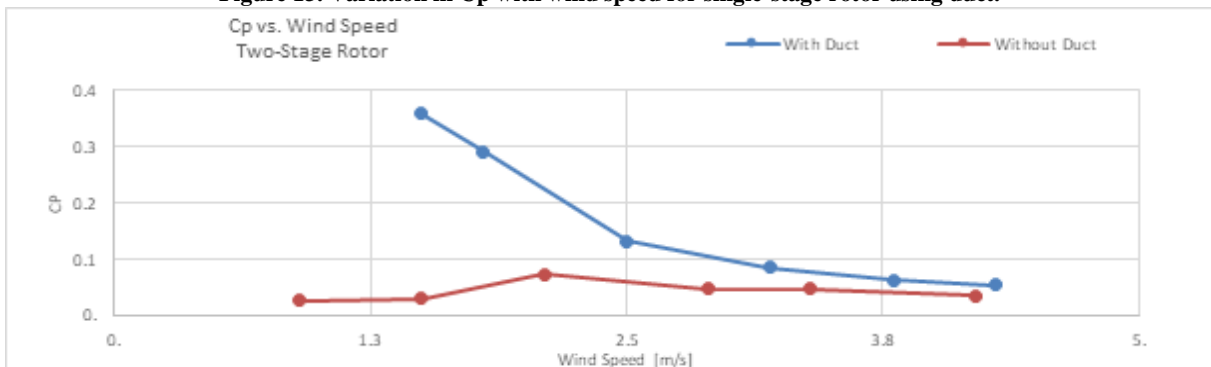

Figure 14. Variation in Cp with wind speed for two-stage rotor using duct.

Figures. 11, 12, 13, and 14 show drastic improvements in Power produced and  $C_p$  when the turbines are used with a converging duct.  $C_p$  does drop greatly with increase in wind speed in case of duct; however, it is still greater when the rotor is used without duct for all speed ranges.

## 5. Conclusion

In this work, the following concepts have been introduced and tested experimentally in a wind tunnel:

- A concept of using a converging duct, and the rotor was also introduced.
- End-plates were implemented to arrest movement of air, and the same was tested experimentally.
- A comparison between the use of a single-stage and double-stage rotor was also done.

Conclusions from the experimental results:

- The result for the single- and double-rotors with and without end-plates showed that using the end-plates TSR and the velocity of blades increased compared without end-plates.
- It was also found that with the use of duct, power output and  $C_p$  increased drastically, especially at low wind speeds.
- Single-stage performs better at lower wind speeds (less than  $\sim 2$  m/s), and the double-stage turbine outperforms, however, marginally, at higher wind speeds.

It can be seen that power generation can increase more than 10 folds. This paper also compares the turbine's performance with and without endplates and compares Single-Stage and Double-Stage Turbines. The experimental results showed around 15% increase in the tangential blade velocity in a single-stage rotor when end-plates were used.

Innovative design and development of vertical axis wind turbine with duct, and end-plates for a given power output was accomplished. The combination of these concepts in design show much promise to lower the cost to manufacturers with enhanced performance that may give viable solution to green energy production.

The limitations to the current set of experiments were:

1. The use of a basic FDM 3D printer, which had a limited work volume and could print products of not very quality surface finish using particular materials. A larger and a better quality 3D printer, making products with better surface finish and strength may be used. In the SLS type, printer can be used for the best results.
2. The speed range and limited cross-sectional test section area of the wind tunnel posed a

challenge to accommodate and test a larger turbine. A larger feature rich wind tunnel can be used for testing a greater range of working speeds and larger turbines.

## Acknowledgment

The authors would like to thank Sanjay Singh, Mahipal Singh, Sunil Gupta, Amit Kumar, Vishal Gaur, and Narender Kumar, Lab Assistants, Shiv Nadar University for their help in establishing the experimental set-up.

## Abbreviations, Notations, and Nomenclature

A	Swept Area of the turbine
$C_p$	Coefficient of Power
D	Diameter of the turbine
d	Diameter of turbine blades
e	Spacing between blades
H	Height of turbine
$P_o$	Power Output by the wind turbine
$P_\omega$	Total Wind Power available
R	Radius of the turbine
rpm	Turbine speed in revolutions per minute
VAWT	Vertical Axis Wind Turbines
$\lambda$	Tip Speed Ratio
$\rho$	Density of the air
$\omega$	Angular velocity of turbine in rad/s

## References

- [1] Hansen, J., R. Ruedy, M. Sato, and K. Lo (2010), Global surface temperature change, Rev. Geophys., 48, RG4004, doi: 10.1029/2010RG000345.
- [2] M. Steen, Greenhouse Gas Emissions from Fossil Fuel Fired Power Generation Systems, Institute for Advanced Materials, Joint Research Centre, European Commission.
- [3] Lakshmanan, N & Gomathinayagam, S & P, Harikrishna & Abraham, A & Chitra Ganapathi, S. (2009). Basic wind speed map of India with long-term hourly wind data. Current Science. 96.
- [4] Ryoichi S. Amano, 2017, "Review of Wind Turbine Research in 21st Century", ASME, Journal of Energy Resources Technology, 139(5):050801, 8 pages, Paper No.:JERT-17-1454; doi: 10.1115/1.4037757
- [5] Ashwani K. Gupta, 2015, "Efficient Wind Energy Conversion: Evolution to Modern Design", ASME, Journal of Energy Resources Technology, 137(5):051201-051201-10, JERT-14-1427; doi: 10.1115/1.4030109.
- [6] Nur Alom and Ujjwal K. Saha, 2018, "Four Decades of Research into the Augmentation



Techniques of Savonius Wind Turbine Rotor”, ASME, Journal of Energy Resources Technology, 140(5), 050801, 14 pages, Paper No: JERT-17-1620; doi: 10.1115/1.4038785

[7] Michele Mari, Mauro Venturini and Asfaw Beyene, 2017, “A Novel Geometry for Vertical Axis Wind Turbines Based on the Savonius Concept”, ASME, Journal of Energy Resources Technology, 139(6):061202-061202-9. doi:10.1115/1.4036964

[8] N. H. Mahmoud, A. A. El-Haroun, E. Wahba, M. H. Nasef, 2012, “An Experimental Study on Improvement of Savonius Rotor Performance”, Alexandria Engineering Journal, Volume 51, Issue 1, pp: 19-25.

[9] J. Alexander, B.P. Holownia, 1978, “Wind Tunnel Tests on a Savonius Rotor”, Journal of Industrial Aerodynamics, 3, pp. 343-351.

[10] Norzanah Rosmina, Ahmad Safwan Jauharib , Aede Hatib Mustaamal , Faridah Husind, Mohammad Yusri Hassane, 2015, “Experimental Study for the Single-stage and Double-stage Two-bladed Savonius Micro-sized turbine for Rain Water Harvesting (RWH) System” Energy Procedia, 68, pp. 274 – 281, 2nd International Conference on Sustainable Energy Engineering and Application, ICSEEA.

[11] M. A. Kamoji, S.B. Kedare, S. V. Prabhu, “Experimental Investigations on Single Stage, Two Stage and Three Stage Conventional Savonius Rotor”, 2008, International Journal of Energy Research, 32(10) pp: 877 – 895. DOI: 10.1002/er.1399.

[12] Frederikus Wenehenubun, Andy Saputra, Hadi Sutanto, 2015, “An Experimental Study on the Performance of Savonius Wind Turbines Related With The Number Of Blades” Energy Procedia, 68, pp. 274 – 281, 2nd International Conference on Sustainable Energy Engineering and Application, ICSEEA., Pages 297-304.

[13] Modi, VJ. and Fernando, MSUK., 1989 “On the Performance of the Savonius Wind Turbine”, Solar Engineering J., 11, p 71-76.

[14] B.D. Altan, M. Atilgan, 2008, “An Experimental Study on Improvement of a Savonius Rotor Performance with Curtaining”, Experimental Thermal and Fluid Science, 32, pp: 1673–1678.

[15] Seyed Amir Hosein Jafari, Sina Hassanli, Sina Hassanli, K C. S. Kwok, “Effect of Incident Wind Angle on Power Generation of Building Integrated Wind Turbines”, 2017, Conference: 9th Asia-Pacific Conferences on Wind Engineering (APCWE9) at: Auckland, New Zealand.

[16] A Rosenberg, S Selvaraj and A Sharma, 2014, “A Novel Dual-Rotor Turbine for Increased Wind Energy Capture”, Journal of Physics: Conference Series. Volume 524, Conference 1, The Science of Making Torque from Wind 2014 (TORQUE 2014) 012078, doi: 10.1088/1742-6596/524/1/012078.

[17] I.H. Al-Bahadly and A.F.T. Petersen, 2011 “A Ducted Horizontal Wind Turbine for Efficient Generation”, Open access peer-reviewed chapter, Wind Turbines, IntechOpen, doi: 10.5772/15050.

[18] Mahdi Ramezanizadeh, Mohammad Alhuyi Nazari, Mohammad Hossein Ahmadi, LingenChen, “A review on the approaches applied for cooling fuel cells”. Int. J. of Heat and Mass Transfer, August 2018, Volume 139, pp: 517-525.

[19] Mahdi Ramezanizadeh, Mohammad Alhuyi Nazari, Mohammad Hossein Ahmadi, Emin Açikkalp, “Application of nanofluids in thermosyphons: A review”, Journal of Molecular Liquids, December 2018, Volume 272, pp: 395-402.

[20] Mahdi Ramezanizadeh, Mohammad Alhuyi Nazari, Mohammad Hossein Ahmadi, Giulio Lorenzini, Ravinder Kumar, Ravindra Jilte, “A review on the solar applications of thermosyphons”, Mathematical Modelling of Engineering Problems, December 2018, pp: 275-280. 10.18280/mmep.050401.

[21] Mahdi Ramezanizadeh, Mohammad Hossein Ahmadi, Amin Puia, Giulio Lorenzini, Ravinder Kumar, Ravindra Jilte, “Applications of nanofluids in geothermal: A review”, Mathematical Modelling of Engineering Problems, December 2018, 10.18280/mmep.050402.

[22] Mishra N, Gupta A, Dawar J, Kumar A, Mitra S., “Numerical and Experimental Study on Performance Enhancement of Darrieus Vertical Axis Wind Turbine With Wingtip Devices”. ASME. J. Energy Resour. Technol. 2018; 140(12):121201-121201-7. doi:10.1115/1.4040506.