

# Design, Fabrication, and Performance Evaluation of Four-reflector Solar Baking Oven

Gwani Mohammed\*, Umar. Abdullahi Bello and Abubakar Gado

*Department of Physics, Kebbi State University of Science and Technology, Aliero Kebbi State, Nigeria..*

Received Date 29 April 2023; Revised Date 19 June 2023; Accepted Date 21 June 2023

\*Corresponding author: gwanimohammed@gmail.com (Gwani Mohammed)

## Abstract

Traditional cooking methods using fuel woods can pose very serious challenges of local and regional air pollution and land degradation. These methods are inefficient, unsustainable, and have serious implications to the environment. To overcome these challenges, a novel four-reflector solar baking oven has been designed and tested for application in rural areas. The solar baking oven consists of four-reflectors made from plane mirrors which reflect the Sun's rays to the absorber plate placed at the baking chamber. The four-reflector intensify the incoming solar radiation into the baking chamber and increase the thermal properties and efficiency of the oven thereby resulting in shorter cooking time. The result obtained from the study showed that the oven can attain high temperature values. The temperature values are higher when the oven is loaded compared to when the oven is unloaded. When the oven is unloaded, the highest temperature attained by the four reflector solar baking oven is 121.6 °C at 13:00 pm, as compared to 133 °C at 13:00 pm, when the oven is loaded. Furthermore, the solar insolation varies with time and the study indicates that the maximum value of solar insolation is 940 w/m<sup>2</sup> in all the two condition. Moreover, the economic analysis indicates that the payback period is 2.3 year and it is viable for application in the rural area.

**Keywords:** *Reflectors, Flat plate collector, Baking oven, solar radiation, Mirrors.*

## 1. Introduction

Energy is considered a prime agent in wealth generation and a significant factor in the economic development of any nation [1]. Currently, fossil fuels still have the highest share of energy consumption globally because it contributes about 80% of the global energy demand despite their environmental depletion [2]. However, owing to the commitments to reduce the greenhouse gas emission from the burning of fossil fuels and to make available sufficient and clean energy to both the developed and developing countries, efforts are made by various nations to supplement their energy base with renewable energy sources. In this view, renewable energy has become a critical component to both researchers and governmental organizations by ever increasing the quantity of generated power from renewable energy sources [3]. Despite the huge development that is recorded on renewable energy technologies, most under-developed and developing nations still considers fuel wood as the primary energy source due to its availability and low cost. However, this has led to ecological problems of deforestation and environmental

pollution. Substantial percentage of the energy requirement in rural areas of Asia and Africa is for cooking and other domestic activities. Hence there is need for clean cooking solutions [4].

Cooking energy accounts for the majority of energy usage in most African nations, including Nigeria, because wood is the primary fuel for cooking in these nations which makes deforestation rate to be very high due to the rising need for fuel wood for cooking [5]. Energy requirements for cooking in developing countries cover approximately 36% of the total energy requirement. The energy crisis and dependence on non-renewable resources, such as wood, oil and gas for cooking are the major reason for pollution, global warming, and severe health hazards to human [6].

Globally, the resultant air pollution from the use of fuel woods, dungs, coal, and other.

Traditional fuel is responsible for more than 1.5 million deaths a year, mostly of women and young children under the age of five who are often been carried at the back of their mothers during the cooking process [7]. The high level of

solid-fuel usage, combined with the inefficient and unsafe traditional cooking stoves, can lead to a public health crisis. Subsequently, millions in Africa suffer from chronic illness caused by Household Air Pollution (HAP) as a result of solid fuel cooking emissions. Additionally, the use of fuelwood, charcoal, crop waste and coal, contributes to a wide range of negative environmental and climate change effects [8]. Figure 1 shows the percentage of households cooking outdoor in the sub-Saharan Africa. It is very clear from the figure that the highest percentage of outdoor households cooking is found in Sierra Leone, with the least percentage of outdoor cooking in Ethiopia.

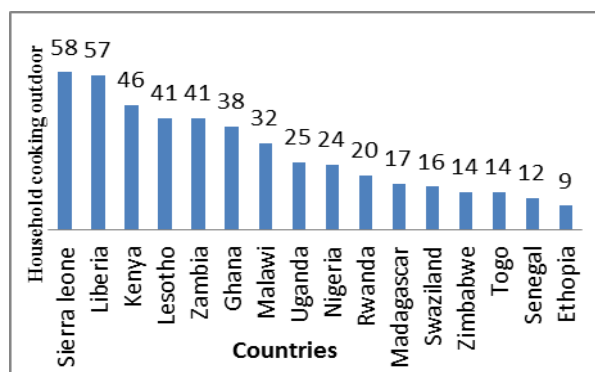

Figure 1. Share of household cooking outdoor in some sub-Sahara countries [8].

In Nigeria, fuel wood is one of the most common energy sources in the rural areas for cooking purpose. Based on the figure presented in figure 1, Nigeria accounts for 24% of the household cooking outdoor in the sub-Sahara Africa. It is evident from the results in figure 1 that access to a clean form of energy, with little or no polluting emissions and having environmental friendly technology, is one of the major challenges of the 21<sup>st</sup> century [9]. Figure 2 shows a typical way of using fuel wood for cooking purpose in the rural areas.



Figure 2. Fuelwood use for cooking [8].

Solar energy is the most readily available and environmentally friendly source of energy among other renewable energy sources. Materials/components needed for the fabrication of solar energy technology are economically viable and available low cost materials. The solar intensity varies with location, season, time of the day (peaking at solar noon and declining to a minimum at sunset). The time of day, the day of the year, and the amount of cloud cover determines the amount of radiation that reaches any particular point on the ground [10].

## 2. Solar cooker/oven

Solar cooker/oven basically consist of an insulated box with a transparent glass cover and reflective surfaces which direct sunlight into the cooking/baking chambers for cooking/baking purposes as depicted in figure 3 [11]. Solar cookers are basically classified into three major types as shown in figure 4. These include solar box cooker, solar parabolic and solar panel cookers [2]. To maximize the sunlight absorption, the inner part of the solar box cooker is usually painted black [12; 13], and each component of the solar box cooker is optimized to maximize the efficiency [11]. Several studies have been conducted by researchers in an effort to enhance the designs, as well as developing and testing different solar cookers at different geographical locations and under unique climate and physical conditions around the world.

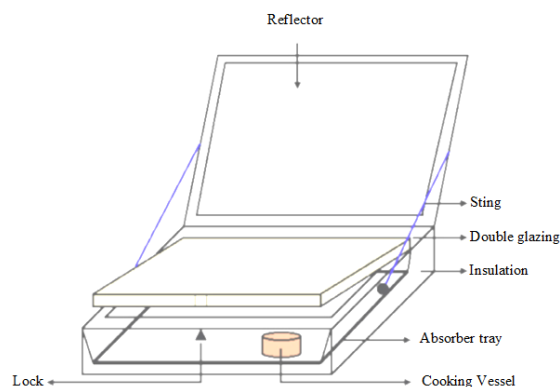

Figure 3. Component of solar box cooker [11].

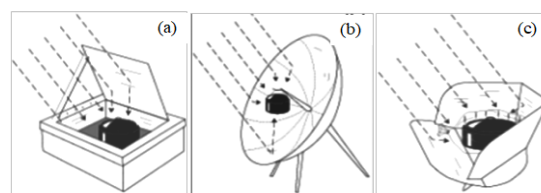

Figure 4. Various types of solar cooker (a) solar box cooker, (b) solar parabolic cooker, (c) solar panel cooker [2].

In the study conducted by [14], several designs of solar cookers were investigated in order to optimize its performance. The results indicated that the proposed new cooker can provide higher temperatures through-out the day and round the year and the cooker could be used for preparation of two meals in a day. The study performed by [15], investigated the effects of the cookers orientation on its performances. The results indicated that the reflector tilt angle and the elevation angle are related by the relationship  $3R - 2R = 180^\circ$  and the cooker which satisfies these conditions gives the best performance.

The performance of box type solar cooker is largely dependent on the glazing material used. It is a well-known fact that there are various glazing materials, which are commonly utilized for solar cookers, which includes, glass, fiberglass, and acrylics, with single and double pane glass receiving higher solar transmission [11]. Harmim et al. [16], asserted that a box-type solar cooker equipped with fins is 7% more efficient compared to the conventional box type cooker without fins and that the time required for heating water reduces by 12%. The study conducted by [17], asserted, that a better performance could be achieved if the external surface of the absorbing top plate is treated with selective coating compared to the simple black coated absorber tray. Singh et al. [18] designed a mobile solar baking oven for baking cookies. The oven consists of four compartment baking compartment, pebble storage, receiver, and blower compartment; the results obtained from the study showed that the design can save up to Rs.5264 of fuel cost per year and cuts up to 213.8 kg of CO<sub>2</sub> emission per year compared to a diesel-power oven. Ugwu *et al.* [19] designed and fabricated a solar powered baking oven using locally available materials, the results obtained from the study showed that the oven can attain up to 98 °C baking temperature. Iwuoha and Ogunedu [20] design and construct a domestic solar cooker, the results obtained from the performance evaluation showed that solar insolation value plays a major role in the performance of solar cooker, according to the study an increase in solar insolation value increases the heating rate thereby reducing the cooking time. Xie *et al.*, [21] study the thermal performance of solar oven based on phase-change heat storage, results from the study indicates that adding phase-change heat storage layer makes the oven inner wall temperature to increase by 30 °C-80 °C higher than without phase-change heat storage layer.

Based on the related literature, it is clear that most of these constructed solar cookers uses only single reflector to concentrate the solar rays into the cooking chamber; in view of these, this study presents a novel solar oven that uses four reflectors to concentrate the solar radiation into the baking chamber with a aim of improving the performance of the solar oven. The solar oven consists of four reflectors made from plane mirrors that concentrate the sun rays into the oven chamber. These four reflectors will increase the efficiency of the oven and reduce the cooking/baking time compared to the single reflector oven/cooker. To the best of the author's knowledge, there is no solar oven that was design with four reflectors for similar purposes.

### 3. Design description of solar baking oven

The four reflectors solar baking oven consists of double wall box with an aluminum tray and a rectangular shape. A galvanized steel sheet was used to fabricate the outer box of the oven. The inner box which is used as the absorbing surface is made of double walled aluminum sheet with black surface. The tray of the oven is enclosed in a box which is made of ply-wood. The box is filled with fiberglass wool insulator. The dimension of the outer box is 75 cm x 30 cm with a slant height of 80 cm and that of the inner wall is 60 x 25 cm, respectively, with a height of 65 cm as shown in figure 5. The Isometric view of the four reflector solar oven showing the oven chamber is shown in figure 6, while the CAD design and the schematic diagram is presented in figure 7 and figure 8 respectively. The space between the inner tray and the outer box was filled with glass wool insulator. To increase the thermal conductivity of the solar cooker, the inner tray (absorber plate), which is the baking chamber, is painted black. The baking chamber is covered with a transparent 75 cm x 75 cm glass cover which transmits the incoming solar radiation into the baking chamber and prevents heat loss from the oven. The oven was designed with four reflectors which are made from plane mirrors of size 75 cm x 75 cm with 4 mm thickness. The four reflectors consist of a wooden frame, which was fabricated using plywood and act as a cover for the solar oven when not in use (Table 1). The desired characteristics of the construction materials are due to its availability low cost, high efficiency and durability and easy to handle during fabrication. The tilt of each reflector can be varied from 0° to 120° from the horizontal plane depending on the season. The baking chamber is shallow and cylindrical in

shape thus reducing the shadow effect from the sidewall, which eventually reduces the heat loss. The baking vessel is made of 0.8 cm cylindrical shaped aluminum sheet painted with dull black color with a flat base. The shape of the oven permits a higher radiation input during the morning and afternoon hours when the oven is in stationary mode. The access to the baking chamber for loading and unloading is possible through a small door at the back of the oven, the dimension of the door is 30 cm x 15 cm, a small lid has been provided to avoid heat loss due to loading and unloading, the loading vessel has handle that can facilitate the loading and unloading in the oven. The Materials used for the design of the solar baking oven is presented in table 1. It can be seen from the table that 4 plane mirrors.

Table 1. Material selection for the solar oven.

Materials	Quantity
Plane mirrors	4
Plane glass	1
Plywood thickness	2 inch
Aluminum sheet	-
Black paint	-

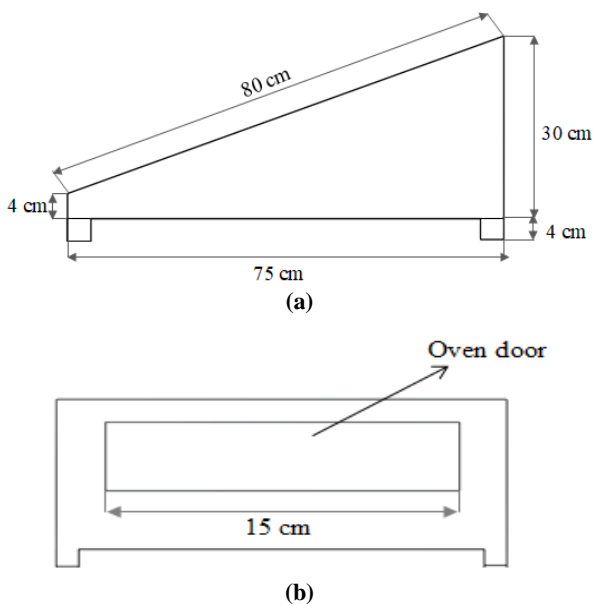

Figure 5 (a and b). Detail dimension of four-reflector solar baking oven.

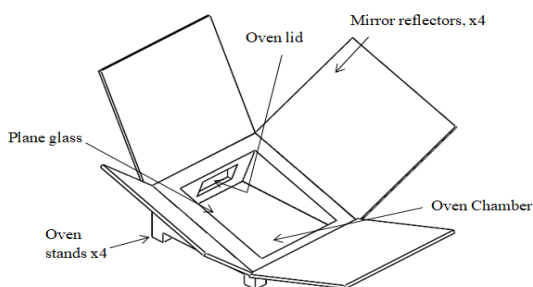

Figure 6. Isometric view of four reflector solar oven showing oven chamber.

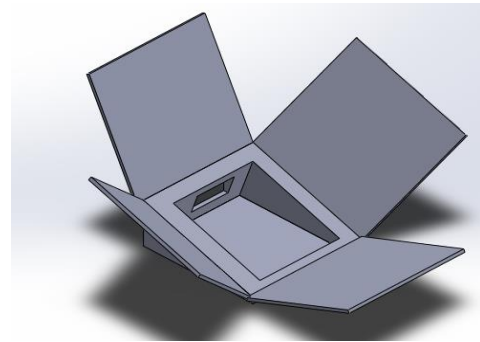

Figure 7. CAD design of the solar baking oven.

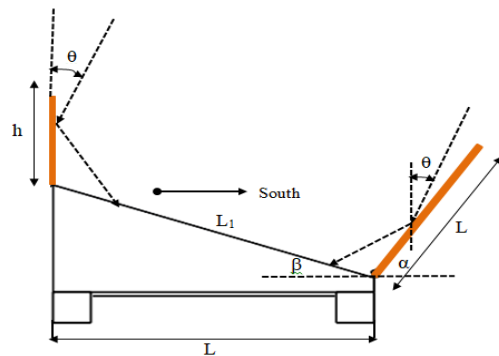

Figure 8. Schematic diagram of the solar baking oven and mirror reflectors facing south and another mirror reflector facing the north [2, 14].

### 3.1. Fabrication of oven

The materials used for the fabrication of the solar baking oven must be able to withstand harsh weather, durable and has low cost of maintenance and repairs. The aluminum sheets were used to fabricate the absorber plate, due to its availability, low cost and high resistance to corrosion compared to copper. The thermal conductivity of the aluminum sheet is good with a value of 205 W/mK, and a thickness of 0.01 mm, respectively. The aluminum sheet was coated with black color to provide high radiation and absorb large amount of heat into the baking chamber. Tempered glass with 0.004 m thickness was used as the glazing material for the oven cover. The glass has low reflectivity and high optical transmittance. To achieve the appropriate desired temperature, double-glazing was used. The casing of the solar oven was made of plywood with a thickness of 0.013 m. The four reflectors used for the oven are higgled on the oven box and can be adjusted manually relative to the oven glazing so that all necessary movement are possible to reflect as much solar radiation as possible into the baking chamber. The frame for the reflectors are made from a light weight ply-wood with 0.001 m thickness and using a hacksaw blade the ply wood was cut and a groove was made with the use of

chisel to insert or position the reflectors. The wooden casing is mechanically joined using hinges together with the reflectors and the glass cover. The reflectors (four mirror) of the same size where hugged separately on each side of the triangular box (up, down, right and left) as shown in figure 9.



Figure 9. Four-reflector solar baking oven

### 3.2. Estimating the components of insolation on solar oven.

The component of insolation incident on the solar oven can be estimated using the following assumptions; the position of the solar oven is horizontal with double glazing, the dimensions are equal, with southwards orientation. The reflector angle of tilt and the southward orientation of the solar oven are adjusted regularly so as to completely expose the oven surface to the reflected insolation. The instantaneous insolation,  $I_T$  is given by.

$$I_T = I_b + I_d + I_r \quad (1)$$

$I_b$  and  $I_d$  denote the beam and diffuse components of insolation, and  $I_r$  denotes the beam insolation reflected on the reflector surface [22].

#### 3.2.1 Performance rating of solar oven

The performance of the solar oven can be evaluated and rated based on the climatic parameters using a standard test procedure. Some of these test procedures include boiling of water, no-load stagnation, and cooking tests. Furthermore, the first and second figure of merit can be used to assess the performance rating of this solar cooker [23, 24]. At some quasi steady state, an energy balance equation on a horizontal solar cooker under no-load condition is given by equation (2).

$$\eta_o I_s = U_L (T_{abs} - T_a) \quad (2)$$

where  $I_s$  and  $\eta_o$  are the insolation and optical efficiency, while  $U_L$ ,  $T_{abs}$ , and  $T_a$  are the heat loss factor, absorber plate temperature and ambient temperature respectively at stagnation.

The equation for the energy balance of the water inside the solar oven can be expressed with the following using equation (3):

$$m_w C_w \frac{dT_w}{dt} = F[A I - A U_L (T_w - T_a)] \quad (3)$$

where  $m_w$  is the mass of the water in the cooking pot (kg),  $C_w$  is the specific heat of water.  $T_w$  is the water temperature,  $T_a$  is the ambient temperature,  $F$  is the heat exchange factor between the pot and the water,  $A$  is the surface of the cooking pot,  $U_L$  is the total coefficient of heat loss,  $I$  is the total radiation that impacts the pot.

The cooking power ( $P_i$ ) is calculated based on the standard ASAE S580 which is given by equation (4).

$$P_i = \frac{(T_f - T_i) MC}{600} \quad (4)$$

where  $P_i$  is the cooking power (W),  $T_f$  is the final water temperature ( $^{\circ}C$ ),  $T_i$  is the initial water temperature ( $^{\circ}C$ ), and  $MC$  is heat capacity of the water ( $JK^{-1}$ ), while the standardized cooking power  $P_s$  can be determined by correcting the cooking power to a standard insolation of  $700 \text{ w/m}^2$  given by equation (5).

$$P_i = \frac{P_i \times 700}{I_s} \quad (5)$$

The overall thermal efficiency of the oven is can be calculated using equation (6).

$$\eta = \frac{(Q_T - Q_L)}{Q_T} \quad (6)$$

where  $Q_T$  is the total energy (W) and  $Q_L$  is the total energy loss (W) [25], while the thermal energy required for reaching the cooking temperature can be calculated using equation (7).

$$Q = M C_p dt \text{ (KJ)} \quad (7)$$

where  $Q$  is the thermal energy,  $m$  is the mass of the material (Kg),  $c_p$  is the specific energy for the selected material  $Kg/Kg^{\circ}C$ .

For efficient performance of the oven it is desirable to have high optical efficiency and low heat loss. Thus the ratio  $\eta_o / U_L$  is referred to as the first figure of merit,  $F1$  given by equation (8).

$$F1 = \eta_o / U_L = \frac{(T_{ps} - T_{as})}{I_s} \quad (8)$$

If the value of  $F1$  is high, it means that the performance of the oven is better [23]. For this study, taking an average insolation, ambient temperature and plate temperature the value of  $F1$  is calculated to be  $0.1 \text{ Km}^2\text{W}^{-1}$  for the oven. In a period of lower insolation, a lower  $F1$  value may be specified.



#### 4. Experimental set-up and procedures

The experimental set-up of the four reflector solar baking oven is presented in figure 10.



Figure 10. Experimental setup of the solar oven.

The experiment was conducted at the Faculty of Physical Sciences, Kebbi State University of Science and Technology Aliero. The testing site is situated at the Latitude  $4^{\circ} 19' 75''$  and Longitude  $12^{\circ} 45' 39''$ . The performance of the solar oven was investigated by measuring the stagnation temperature and conducting some cooking trials. The tests were conducted under two conditions; (i) no-load and load condition. The no-load condition was necessary to determine the stagnation temperature. For the case of the load conditions, time required for baking a given quantity of bread or to boil water was determined using sensible heat test. Measurements were taken at intervals of 30 minutes, for both the no-load and load conditions, and throughout the effective period of sunshine hours at about 8:00 am to 17:00 pm Local Time. Copper-constantan thermocouples with accuracy of  $0.05^{\circ}\text{C}$  were used to measure the stagnation air temperature inside the baking chambers and the glazing was not opened during the measurements. Other parameters measured during the testing include;

the ambient ( $T_a$ ), and absorber plate ( $T_p$ ) temperature.

#### 5. Results and discussion

Preliminary test has been conducted on the four reflectors solar baking oven to test the thermal performance of the solar oven, sensible heat tests were also conducted to determine the time required to baked a given quantity of bread, boil water and other food items.

##### 5.1. No-load test

Figure 11 shows the variation of insolation and temperatures with time when the oven is unloaded. The results are presented for the insolation, inner temperature ( $T_{in}$ ), the ambient temperature ( $T_a$ ), and Temperature of the plate. The experiment began at 9:00 am to 17:00 pm local time, i.e. for 8 hrs. It is clear from the figure that both the inner temperature and the ambient temperature gradually increase with time and the highest temperature values are recorded during peak sunshine hours. The figure shows that the transient responses of the solar oven follow closely the insolation pattern, which is showing a direct correlation between insolation and the temperature values. The peak values for the inner temperature is  $84^{\circ}\text{C}$ , this peak value is attained at 13:00 pm local time when the sun is directly overhead, at the same time the ambient temperature, and the plate temperature were found to be  $39^{\circ}\text{C}$  and  $121.6^{\circ}\text{C}$ , respectively, while the solar insolation was found to be  $940\text{ Wm}^{-2}$ . The minimum temperatures were obtained in the morning hours when the sun is rising up and the evening hours when the sun sets off.

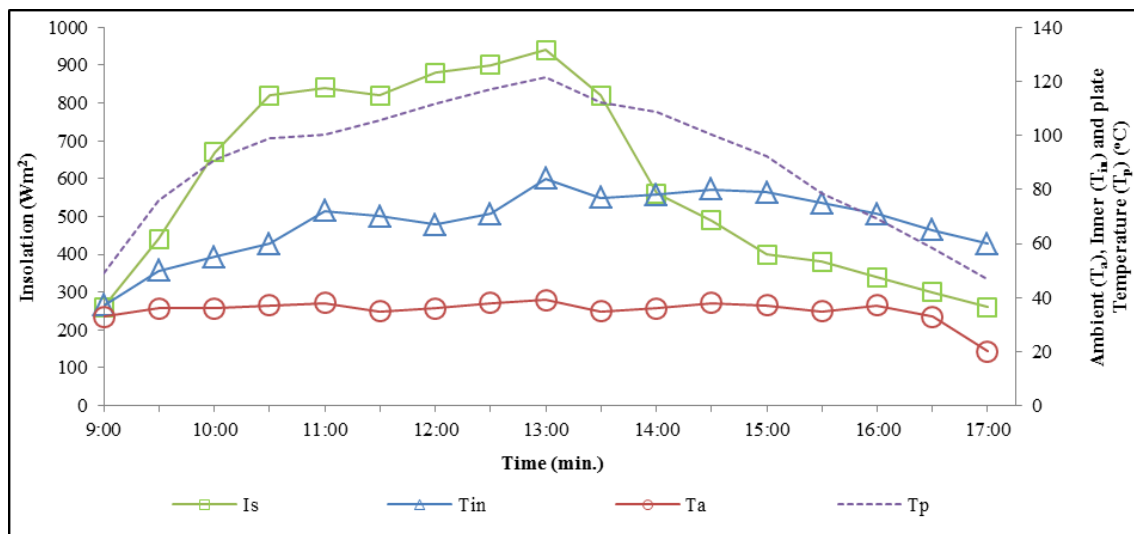

Figure 11. Variation of temperature with time unloaded.

### 5.2. Loaded test

Experiments were conducted by loading the solar oven with four different food items independently; these include water, bread, fish, and meat. The cooking time and boiling time of the food items was recorded and plotted in figure 12. It is clear from the figure that all the temperatures values follow the patterns of insolation. The figure shows the direct correlation between the temperature and insolation. The temperature of the water reaches

its boiling point of 100 °C at 12:00 noon, at this time the inner temperature of the baking chamber has it highest temperature of 77 °C, while the ambient temperature is 35 °C. The peak inner and ambient temperature of 102 °C and 40 °C was obtained at 13:00 pm. From the results it was observed that it took about 3 hrs. to boil 3 liters (3 kg) of water. However, the time taken to reach the boiling point of water might vary due to the weather conditions at that particular point in time.

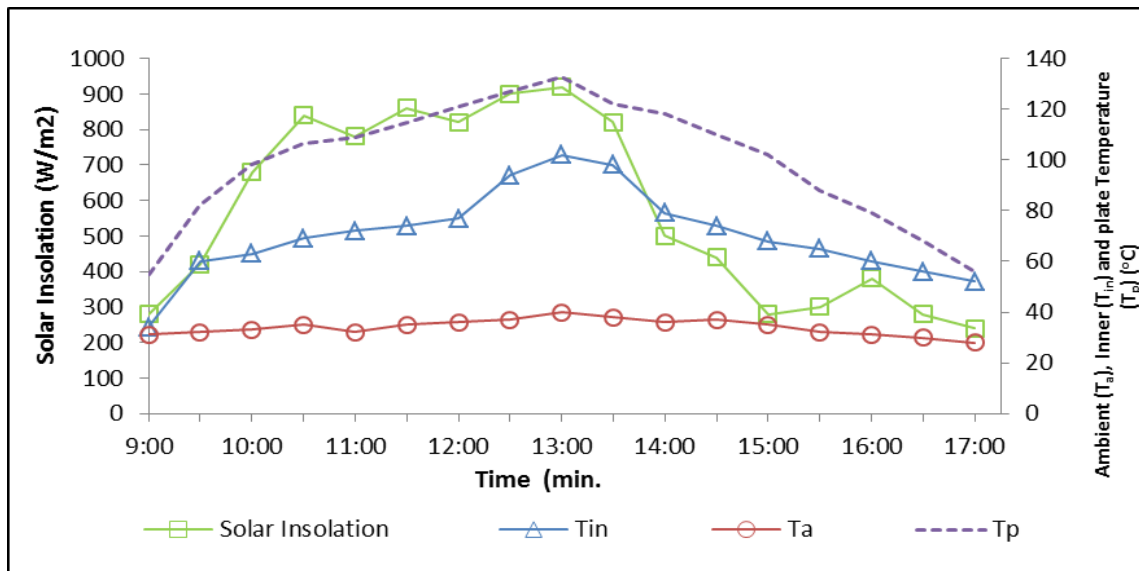

Figure 12. Variation of temperature with time loaded (boiling of water).

Figure 13 shows the variation of temperatures, and solar insolation with time in the solar oven loaded with bread. From the figure, it can be observed that the solar insolation has attained a peak value of 920 Wm<sup>-2</sup> at 13:00 pm. At this value of insolation, the inner temperature of the oven has its highest value of 79 °C. The absorber plate

attains a highest temperature of 131 °C at 13:00 pm, at this temperature; the bread was completely baked. The ambient temperature for this setup is 39 °C at 11:30 am. It can be observed from the figures that it took about 4 hrs. to bake the bread; however, the baking time depends on the quantity or size of the bread and the weather conditions.

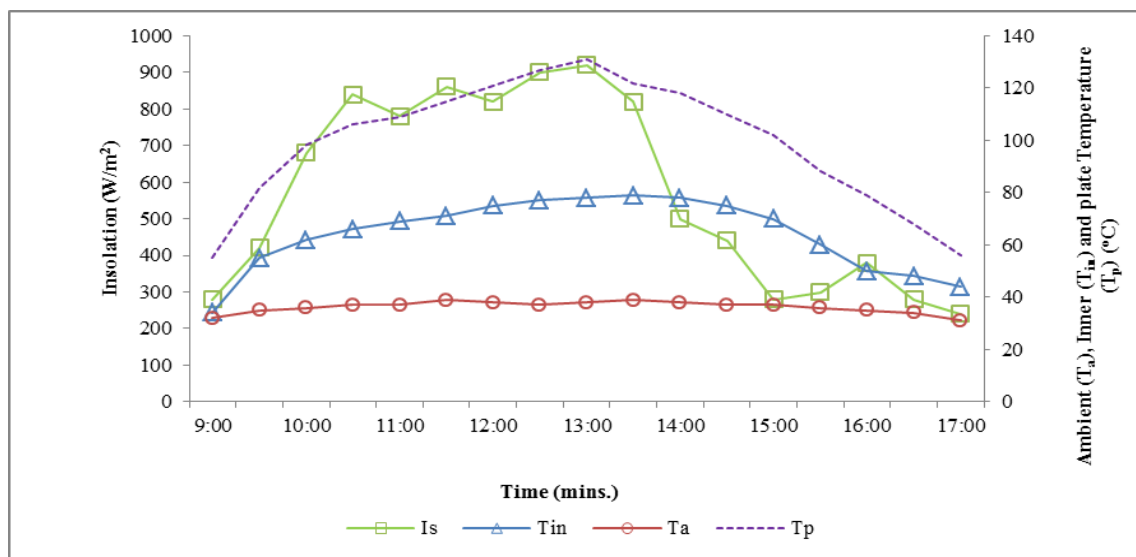

Figure 13. Variation of temperature with time loaded (for baking bread).

The variation of temperatures and solar insolation with time for the roasting of fish is depicted in figure 14. It was observed from the figure that the temperatures in the solar baking oven increases gradually with time, the peak temperatures was attained at about 12:30 pm; at this temperature,

the insolation is also peak with a value of about  $940 \text{ W/m}^2$ . The peak values of the temperature of the observed plate and inner temperature are  $125 \text{ }^\circ\text{C}$ , and  $78 \text{ }^\circ\text{C}$ , respectively; both temperatures were observed at 12:30 pm respectively at a peak ambient temperature of  $39 \text{ }^\circ\text{C}$ .

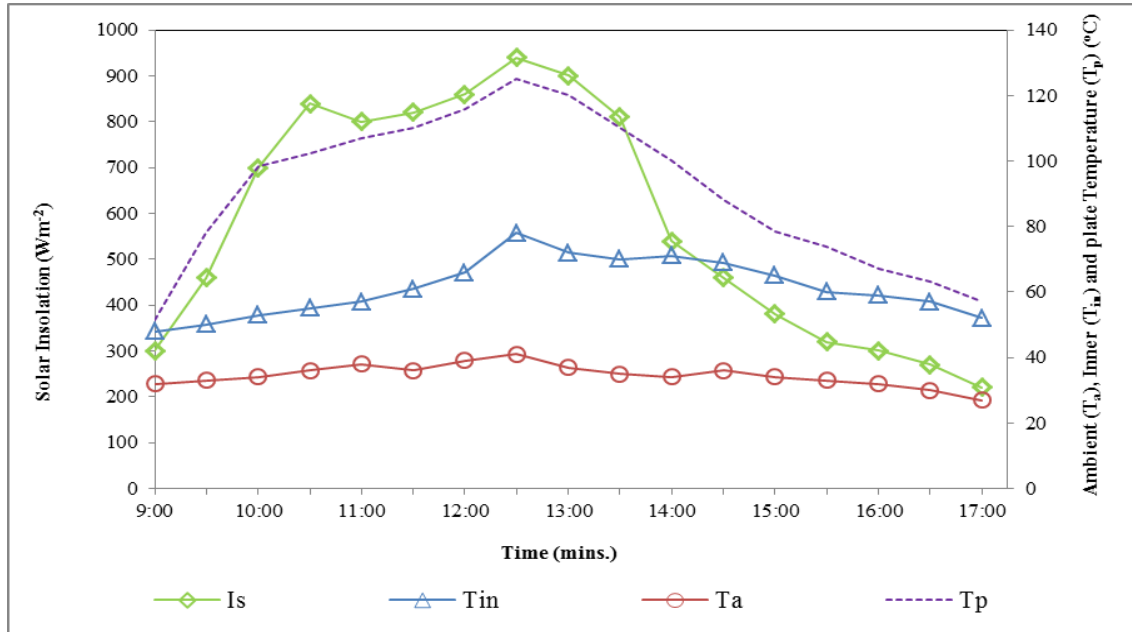

Figure 14. Variation of temperature of the oven, temperature of the plate, and ambient temperature with time for cooking fish.

### 5.3. Performance rating of solar cookers

The performance rating of the solar baking oven was evaluated using figure of merits explained in equation 3, for boiling of water, using equation (3), the first figure of merit  $F_1$  was calculated to be  $0.104 \text{ m}^2\text{KW}^{-1}$ . The efficiency of the solar baking oven has been calculated to be 24.3%, this efficiency is relatively good when compared with the efficiency obtained by Tibebe and Hailu [26] where they obtained 10.75%. However, the efficiency is almost the same with that of Chaudhary and Yadav [27] where in their case they achieved 26.6%, while Khan *et al.* [28] obtained 37.75% in their design. The low efficiency of the solar oven might be attributed to many factors which includes; weather conditions, and type of reflective materials used, etc. Furthermore, the maximum temperature achieved from the constructed solar oven is  $131 \text{ }^\circ\text{C}$ . This temperature is higher compared to the  $96 \text{ }^\circ\text{C}$  obtained by [19] as the highest temperature.

As can be seen from the results obtained the temperature rises and falls with respect to time as the sun moves around its orbit which greatly affects the performance of the oven. It was further observed from the results that the four reflectors solar baking oven performed very well in the

middle hours of the day between 12:00 pm and 14:00 pm, where the temperatures was observed to be at its peak. However, it was noticed that the temperature is usually low during the early and late hours of the day, the reason is due to the fact that at sunrise the altitude angle which describes the angle between the horizontal surface and the incident ray, is zero, this angle gradually increases towards a maximum (90) at midday, and decline to zero again at sunset. Therefore, the most efficient timing for the baking/cooking using the four reflectors solar baking oven is between 12:00 noon 13:30 pm. However, the timing varies from region to region. It was also observed that the insolation level is fairly high and with little variability due to the absence of cloud overcast at the study site. To maximize the radiation entering the oven it is important to orient the reflective surfaces so that they contact the incoming beam radiation in such a way as to minimize the incidence angle and maximized the altitudinal angle. The high performance of the solar baking oven is attributed to the reflective surfaces. The reflectors surrounding the outside of the solar oven were used to further concentrate the incoming rays onto the absorptive surface that will transfer heat to the food being cooked/baked.



The Energy reaching the solar oven is maximized (i.e. energy density per unit area is highest) when the incident ray is hitting the reflective surface most directly (i.e. when the incident angle is closest to zero or the altitude angle is closed to 90) [29].

#### 5.4. Economic analysis

The economic viability of any system can be seen from the cost effectiveness of the system. For this solar oven, to ascertain the viability of the system.

##### 5.4.1. Payback period

Consider the cooking capacity of solar oven is for family of three (3) persons at a time, and three (3) meal per person, and the cooking energy requirement for one person is 620 Kcal per day, the energy require for cooking is calculated to be 1860 Kcal/day. Assuming 50% of cooking can be met with solar ovens therefore, the energy requirement for cooking is calculated to be 930 Kcal/day, and assuming annual cooking of about 300 days was considered, the annual cooking energy required is calculated to be 279000Kcal, while the energy content of 1 kg of firewood with 60% useful energy utilization (40% loss due to smoke, volatile ash and flame) is calculated to be 28,800 KJ. The cost of 1Kg of firewood is \$1 (NGN 800), while the cost of the solar oven is \$25 (NGN 20,000). The annual savings due to solar oven is calculated to be 8370 (\$10.46), hence the pay-back period 2.3 year.

#### 6. Conclusion

In this study, four reflectors solar baking oven has been successfully designed and experimentally tested. The findings of the study revealed that the performance of the solar baking oven improved greatly with the presence of the four reflectors. The results obtained from the study showed that with the present of the four reflectors in the solar oven design, the oven could attain high temperature values when the oven is loaded compared to when the oven is unloaded. This novel design with optimum performance will bring the solar baking oven close to being accepted as a realistic alternative method of cooking. The analysis confirms the figure of merit as a reliable design and performance rating criteria for the solar oven. The solar oven has the potential to ease the work of the women or people in the rural community thus reducing the demand of wood fuel from the forest and thus making our forest to regenerate again. However, further work can be done to improve the performance of the solar oven by using more reflective materials,

moreover, the quality of the cooked food can be tested, and the economic analyses of the solar oven will be carried out in future work.

#### 7. Acknowledgement

The authors would like to thank Kebbi State University of Science and Technology, Aliero for the financial support provided to carry out this research work.

#### 8. References

- [1] Kalogirou, S. (2003), "The potential of solar industrial process heat applications", *Applied Energy*. Vol. 76, 337–361.
- [2] Erdem, C. and Pinar, M. C. "A (2013), comprehensive review on solar cookers" *Applied Energy*. Vol. 102, 1399-142.
- [3] Toonen, H.M. (2009), Adapting to an innovation: solar cooking in the urban households of Ouagadougou (BurkinaFaso). *Phys Chem Earth* 34: p. 65–71. <https://doi.org/10.1016/j.pce.2008.03.006>.
- [4]. Gado A. and Muthukumar M. (2017) "Solar Energy for Electricity Generation-A Comparative Study of Three States in India". *Proceeding of the 1st International Conference on Large-Scale Grid Integration of Renewable Energy in India*. 6-8 September New Delhi.
- [5] Yamikani K., Mlatho, J.S.P, Kondwani C.C. M, Thesaurus C. N. (2022) Design Construction and Performance Evaluation of Box and Parabolic Solar cooker. *international Journal of Innovative Science and Research Technology*, Volume 7, Issue 6, ISSN No. -2456-2165.
- [6] Navendu M. Abhishek A., Saurabh, P., Karunesh K., Amritanshu S., and Atul S. (2023) Box-type Solar Cookers: An Overview of Technological Advancement, Energy, Environmental, and Economic Benefits. *Energies MDPI* Pp 1-32, <https://doi.org/10.3390/en16041697>.
- [7] WHO (2010) "Health in green economy: Household energy sector in developing countries Public health and environment department.
- [8] ACCESI, (2014) "Africa Clean Cooking Energy Solution Initiative; an improved cooking in Sub-Saharan Africa". In W. b. group (Ed.), *Second Edition* (Vol. A land scape report).
- [9] Gwani M., and Abubkar G. A (2016) .Power Sector Challenges and Renewable Energy Potentials in Nigeria, *International Journal of Engineering Research and Science & Technology*, Vol. 5(1). 76-84. ISSN: 2319-5991.
- [10] Holladay, A., *Solar Energy*, Microsoft student 2008. Redmond WA ® Encarta @ 1993-2008, (2009) Microsoft Corporation.

- [11] Saxena, A., Varun, Pandey, S. P., and Srivastav, G., "A thermodynamic review on solar box type cookers" *Renewable and Sustainable Energy Reviews*, Vol. 15 (6), (August 2011), 3301-3318. <https://doi.org/10.1016/j.rser.2011.04.017>
- [12] Khan, B., (2008). "Non-conventional energy resources. McGraw Hill Education".
- [13] Kothari, D., Singal, K., and Ranjan, R., (2008) *Renewable energy resources and emerging technologies*. Prentice-Hall. Prentice-Hall of India Pvt. Limited, India.
- [14] Mirdha, U. and Dhariwal, S. (2008). "Design optimization of solar cooker" *Renewable Energy*, Vol. 33.), 530–544.
- [15] Algifri, A., and Al-Towaie, H., (2001). "Efficient orientation impacts of box-type solar cooker on the cooker performance" *Solar Energy*, 70(2), 165–170.
- [16]. Harmim, A., Belhamel, M., Boukar, M., and Amar, M. (2010). "Experimental Investigation of a box-type solar cooker with a finned absorber plate". *Energy*, 35 (9), 3799–3802.
- [17] Shrestha, V. (1987). "Modification of the solar cooker" *Solar and Wind Technology*, 4(3), 305–311.
- [18] Singh, P, Isaiah, B., and Nagre, V. (2020). *Solar Bakery oven: Energy Design Project*, Department of Energy Science and Engineering, Indian Institute of Technology Bombay Mumbai, 400076, Pp 1-26.
- [19] Ugwu, J. U. Chinedu, K. O., Anietie F. Ogochukwu, N. L. (2021). Design and Fabrication of Solar Powered Baking Oven *Journal of Innovation and Sustainability*, 4, 10-15 ISSN online 0184-7937.
- [20] Iwuoha A.U. and Ogunedo, M (2019) Design and Construction of a Domestic Solar Cooker, *Assian Institute of Research Engineering and Technology Quaterly Reviews* Vol. 2. No. 1, 24-37, ISSN 2622-9374.
- [21]. Xie S., Wang, H., Wu, Q., Yukang L., Zhang Y., Jin, J, and Pei, C. (2019). A Study on the thermal performance of solar oven based on phase-change heat storage. *Energy Exploration and Exploitation*, Vol. 37(5).
- [22]. Taha, I. S. and Eldighidy, S. M. (1980) "Effects of off-south orientation on optimum conditions for maximum solar energy absorbed by flat-plate collector augmented by plane reflector" *Solar Energy*, 25(4), 373 - 379.
- [23] Mullick, S.C., T.C. Kandpal, and A.K. Saxena, (1987). Thermal test procedure for box-type solar cooker. *Solar Energy*, 39(4): p. 353 - 360.
- [24] Mullick, S.C., T.C. Kandpal, and K. Subodh, (1996). Testing of box-type solar cooker: second figure of merit F2 and its variation with load and number of pots. *Solar Energy*. 57(5): p. 409 - 413.
- [25] Iwuoha A.U. and Ogunedo, M,(2021) Performance evaluation and economic analysis of a domestic solar cooker *Open Access Library Journal* Vol. 8 e7263 Pp 1-15
- [26] Tibebe, S., and Hailu, A. (2021). Design, Construction, and Evaluation of the performance of Dual axis sun tracker parabolic solar cooker and comparison of cooker, *Hindawi Journal of Renewable Energy*, Article ID 8944722, P. 1-10, <https://doi.org/10.1155/2021/8944722>.
- [27] Khan, M.S., Abid, M., Amber K. P., Ali, H. M., Yan, M., and Javed, S. (2021). Numerical performnce investigation of parabolic dish solar-assisted cogeneratio plant using different heat transfer fluids, *International Journal of Photoenergy*, Article ID 5512679. 15 pages.
- [28] Chaudhary, R and Yadav A. (2020). Experimental investigation of solar cooking system based on evacuated tube solar collector for the preparation of cncetrated sugarcane juice used jaggery making *Environemt, Development and Sustainability*, Vol. 5 pp, 1-17.
- [29] Pejack E. (2003). *Technology of Solar cooking*. Self Published on internet. University of Pacific, 203.